

F.S

FUSAN



隔膜式
減壓閥

富山精機廠股份有限公司
富鋼股份有限公司





公司簡介

公司名稱：富山精機廠股份有限公司
 PROFILE OF FU SAN MACHINERY CO., LTD.

富鋼股份有限公司

富弦閥門(上海)有限公司

註冊商標：F.S. FUSAN

TRADE MARK: F.S. FUSAN

經營宗旨：精誠勤和

品質政策：以精誠勤和之理念

提昇企業品質，服務社會

追求企業之永續經營

工廠：和美總廠

福興廠

埔鹽廠

蘇州廠(中國)

員工同仁：400名(台灣)

NUMBER OF EMPLOYEE: 400(Taiwan)

產品認證



營利事業登記證

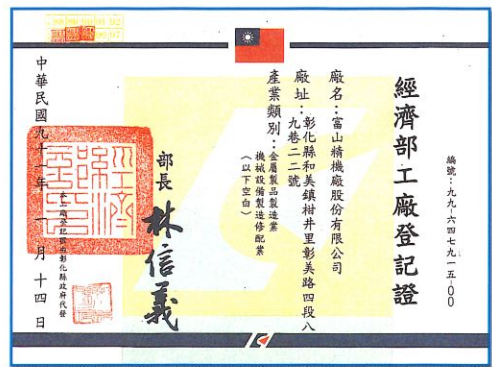

工廠登記證

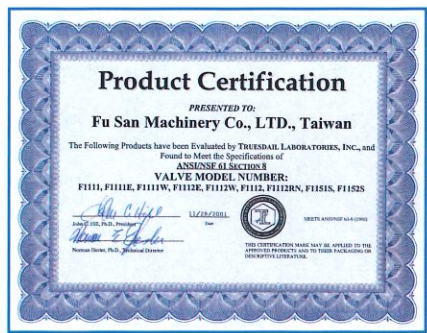

NSF 美國衛生基金國際組織 (閘閥)

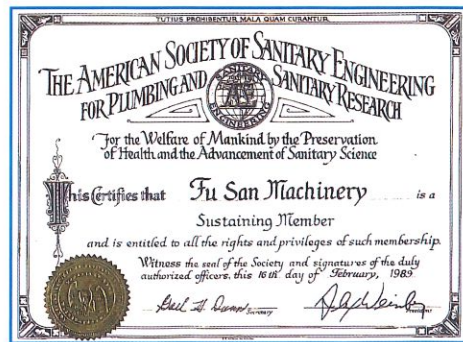

AE 美國衛生工程學會標章



FM 工廠相互研究協會

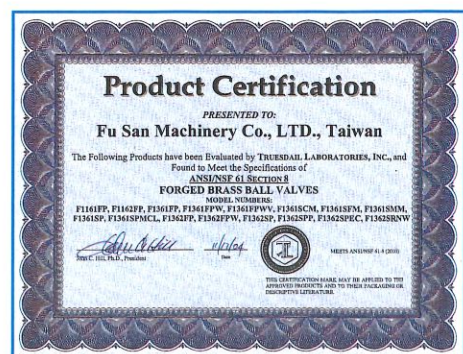

NSF 美國衛生基金國際組織 (球閥)

公 司 沿 革 及 殊 榮

- 1962 公司成立
Company Established
- 1968 產品拓展海外市場
Expanding foreign Market
- 1981 產品外銷日本市場
Exporting product to Japan
- 1984 和美銅閥廠落成
Lived to Ho-Mei factory
- 1986 投資空氣、廢水污染防治設備
- 1987 成立富鋼股份有限公司
- 1991 福興鑄鐵閥門廠成立
- 1992 對外出口首度突破三千萬美元
- 1999 富弦閥門(上海)公司成立
- 2002 埔鹽不銹鋼閥門廠成立
- 2003 蘇州閥門廠(中國)投產
- 2004 中國營運中心(上海)成立
- 2014 蘇州閥門廠(中國)二期投產
- 2018 江蘇塩城閥門廠投產

- 1975 核準使用®字標記
Certification
- 1979 美國AGA認證通過
AGA certification
- 1981 加拿大CSA認證通過
CSA certification
- 1989 美國UL認證通過
UL certification
- ASSE認證通過
ASSE certification
- 1992 韓國KS認證通過
KS certification
- 1994 IAPMO認證通過
IAPMO certification
- 1995 ISO 9002認證通過
BCIQ/ISO 9002 certification
- FM認證通過
- 1998 ISO 9001認證通過
UL/ISO 9001 certification
- 2000 NSF 認證通過

產 品 認 證



國際品保認證

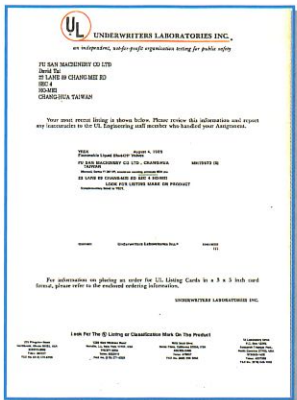

美國保險
實驗室標準



總號713
類號B2107
第7282號



總號11090
類號B2765
第4138號



總號11088
類號B2763
第5556號



總號715
類號B2109
第7283號



總號9805
類號B2740
第3581號



總號9840
類號B2739
第3845號



總號5974
類號B2513
第7284號



Class 10,000 無塵室
禁油洗淨設備



AUTO CAD 研發中心



X-Ray 分光儀材質檢驗機



全自動鍛造設備

索引

產品實績 3-4

產品規格一覽表 5-7

銅系列產品 8-13

不銹鋼系列產品 14-19

鑄鐵系列產品 20-24

球墨鐵系列產品 25-27

多功能平衡閥 28

偏心蝶閥 29

特殊閥 30-36

輔助資料 37-41



GUNTTI 閘閥加工自動化設備



大型閘件CNC加工設備



GUNTTI 球閥加工自動化設備



CNC 綜合加工設備



組立試壓自動化設備



大型蝶閥試壓設備



防結露實驗機

公共工程實績



國家級科學工藝博物館



大型教學醫院

辦公大樓、醫院、石化產業實績



MALL購物中心



超高層大樓



軟件研發中心



現代化高科技廠房



石化相關產業

無塵(菌)室製程設備—全不銹鋼閥使用實例



超純水機房



特殊氣體機房



無塵室廠房

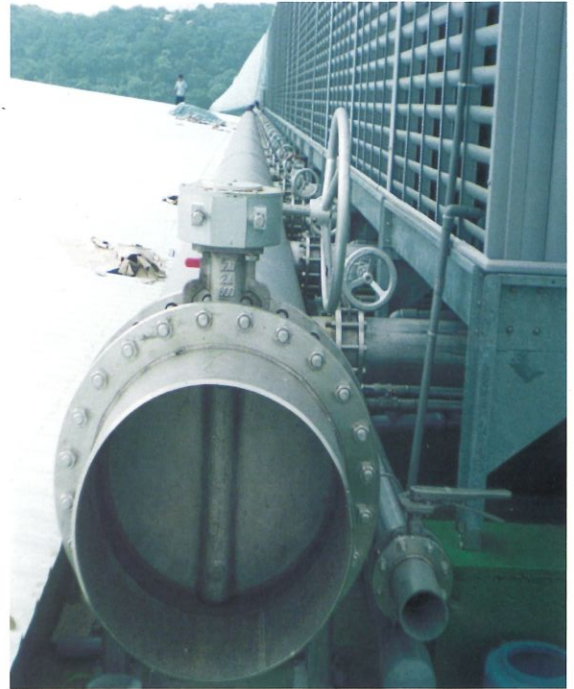

24"不銹鋼蝶閥使用實例



控制閥使用實例



動力機房



空調機房



熱交換機房



消防機房 16K閥使用實例

10K 相關用閥使用實例

富山 產品規格一覽表

材質	標稱壓力	品名	產品編號	15	20	25	32	40	50	65	80	100	125	150	200	250	300	頁次	備註		
				m/m 1/2" inch	3/4"	1"	1-1/4"	1-1/2"	2"	2-1/2"	3"	4"	5"	6"	8"	10"	12"				
黃銅	牙	YBsC3	125S	閘門閥	FS-101	●	●	●	●	●	●	●						8	最小生產尺寸至1/4"		
	口	YBsC3	125S	橫式逆止閥	FS-201	●	●	●	●	●	●	●							8		
		C3771BE	600wog	鍛造球塞閥	FS-301	●	●	●	●	●	●	●							8	最小生產尺寸至1/4"	
鈹金銅	牙	BC	125S	閘門閥	FS-103	●	●	●	●	●	●	●							9		
		BC	300wog	昇桿式閘門閥	FS-104	●	●	●	●	●	●	●							10		
		BC	300wog	閘門閥	FS-109	●	●	●	●	●	●	●							10		
		BC	125S	橫式逆止閥	FS-203	●	●	●	●	●	●	●	●						9		
		BC	300	無聲逆止閥	FS-204	●	●	●	●	●	●	●							9		
		BC	300wog	橫式逆止閥	FS-209	●	●	●	●	●	●	●							10		
		BC	600wog	球塞閥	FS-303	●	●	●	●	●	●	●							11		
		BC	150S	球型墊片閥	FS-404	●	●	●	●	●	●	●							11		
		口	BC	16K	減壓閥	FS-501	●	●	●	●	●	●								11	
			BC	15K	自動釋氣閥	FS-601	●	●	●											12	
	BC		10K	水錘吸收器	FS-701	●	●	●	●	●	●	●							12	1/2" - 2" 外牙式 2 1/2"-3" 內牙式	
	法蘭	BC	10K	水錘吸收器	FS-702					●	●	●	●	●	●				13		
	牙	BC	300	Y型過濾器	FS-803	●	●	●	●	●	●	●							13		
法蘭		BC	10K	閘門閥	FS-020					●	●	●	●					13			
不銹鋼	牙	CF8M	300PSI	閘門閥	FS-111	●	●	●	●	●	●							14			
		CF8M	300PSI	橫式逆止閥	FS-211	●	●	●	●	●	●							14			
		CF8M	1000型	一片式球塞	FS-311	●	●	●	●	●	●							15			
		CF8M	1000型	二片式球塞	FS-312	●	●	●	●	●	●	●						15	最小生產尺寸至1/4"		
		CF8M	1000型	三片式球塞	FS-313	●	●	●	●	●	●	●						15	FS-313S 套焊式 FS-313B 對焊式		
		CF8M	1000型	加長對焊球塞閥	FS-313L	●	●	●	●	●	●	●						16			
		CF8M	300PSI	Y型墊片球型閥	FS-411	●	●	●	●	●	●							14			
	口	304	16K	減壓閥	FS-511	●	●	●	●	●	●							11			
		304	10K	自動釋氣閥	FS-612	●	●	●										12			
		304	10K	水錘吸收器	FS-712							●	●	●	●			13			
		CF8M	300型	Y型過濾器	FS-811	●	●	●	●	●	●							16			
	法蘭	口	304	10K	球塞閥	FS-030	●	●	●	●	●	●	●	●	●	●	●	●	16	FS-030M 材質316 FS-030K JIS-16K	
			304	10K	昇桿式閘門閥	FS-031						●	●	●	●	●	●	●	17	FS-031M 材質316 FS-031K JIS-16K	
			304	10K	橫式逆止閥	FS-032						●	●	●	●	●	●	●	17	FS-032M 材質316 FS-032K JIS-16K	
			304	10K/10K	Y型過濾器	FS-033						●	●	●	●	●	●	●	17	FS-033M 材質316 FS-033K JIS-16K	
		口	304	10K	球型閥	FS-034						●	●	●	●	●	●	●	18	FS-034M 材質316 FS-034K JIS-16K	
304			10K	拉柄式底閥	FS-035						●	●	●	●	●	●	●	18	FS-035M 材質316 FS-035K JIS-16K		
304			10K	蝶型閥	FS-037						●	●	●	●	●	●		19	FS-037M 材質316 FS-037K JIS-16K		
304			10K	齒輪式蝶型閥	FS-038						●	●	●	●	●	●	●	19	FS-038M 材質316 FS-038K JIS-16K		
304			10K	雙瓣式逆止閥	FS-039						●	●	●	●	●	●	●	19	FS-039M 材質316 FS-039K JIS-16K		
304			10K	無聲逆止閥	FS-040						●	●	●	●	●	●	●	18	FS-040M 材質316 FS-040K JIS-16K		
蘭	口	304	10K	偏心式蝶閥	FS-021						●	●	●	●	●	●	29				
		304	10K	偏心齒輪蝶閥	FS-022							●	●	●	●	●	●	29	夾心式可承製48"		

富山產品規格一覽表

材質	標稱壓力	品名	產品編號	50	65	80	100	125	150	200	250	300	350	400	450	500	600	頁次	備註		
				m/m	2"	2-1/2"	3"	4"	5"	6"	8"	10"	12"	14"	16"	18"	20"			24"	
鑄鐵	法蘭	FC	10K	蝶型閥	FS-041	●	●	●	●	●	●	●						20			
		FC	10K	齒輪式蝶型閥	FS-042	●	●	●	●	●	●	●	●	●	●	●	●	●	20		
		FC	10K	蝶型閥	FS-043	●	●	●	●	●	●	●	●						20	ST 葉片	
		FC	10K	齒輪式蝶型閥	FS-044	●	●	●	●	●	●	●	●	●	●	●	●	●	●	20	ST 葉片
		FC	10K	全耳式蝶型閥	FS-045	●	●	●	●	●	●	●	●						21	ST 葉片	
		FC	10K	全耳式蝶型閥	FS-046	●	●	●	●	●	●	●	●	●	●	●	●	●	●	21	ST 葉片
		FC	10K	閘門閥	FS-051	●	●	●	●	●	●	●	●	●					22		
		FC	10K	昇桿式閘門閥	FS-052	●	●	●	●	●	●	●	●	●					22		
		FC	10K	橫式逆止閥	FS-071	●	●	●	●	●	●	●	●	●					22		
		FC	10K	橫式逆止閥	FS-072	●	●	●	●	●	●	●	●	●					23		
		FC	10K	無聲逆止閥	FS-073	●	●	●	●	●	●	●	●	●					23		
		FC	10K	雙瓣式逆止閥	FS-074	●	●	●	●	●	●	●	●	●	●	●	●	●	●	23	
		FC	10K	拉柄式底閥	FS-075	●	●	●	●	●	●	●	●	●					24		
		FC	10K	Y型過濾器	FS-081	●	●	●	●	●	●	●	●	●	●	●			24		
		FC	10K	球型閥	FS-091	●	●	●	●	●	●	●	●	●					24		
球墨鐵	法蘭	FCD	16K	昇桿式閘門閥	FS-011	●	●	●	●	●	●	●	●					25	F5011DK JIS-20K		
		FCD	16K	橫式逆止閥	FS-012	●	●	●	●	●	●	●	●	●					25	F5012DK JIS-20K	
		FCD	16K	Y型過濾器	FS-013	●	●	●	●	●	●	●	●	●	●	●			25	F5013DK JIS-20K	
		FCD	16K	球型閥	FS-014	●	●	●	●	●	●	●	●	●					26	F5014DK JIS-20K	
		FCD	16K	蝶型閥	FS-015	●	●	●	●	●	●	●	●	●					26		
		FCD	16K	齒輪式蝶型閥	FS-016	●	●	●	●	●	●	●	●	●	●	●	●	●	●	26	
		FCD	16K	無聲逆止閥	FS-017	●	●	●	●	●	●	●	●	●					27	F5017DK JIS-20K	
		FCD	16K	雙瓣式逆止閥	FS-018	●	●	●	●	●	●	●	●	●					27		
		FCD	16K	拉柄式底閥	FS-019	●	●	●	●	●	●	●	●	●					27		
		FCD	10K/16K	偏心式蝶閥	FS-021D		●	●	●	●	●	●	●	●					27		
		FCD	10K/16K	偏心齒輪蝶閥	FS-022D		●	●	●	●	●	●	●	●	●	●	●	●	●	27	
特殊閥	隔膜式	304	10K	減壓閥	FS-065S	●	●	●	●	●	●	●	●					30			
		304	10K	持壓閥	FS-066S	●	●	●	●	●	●	●	●					31			
		304	10K	定水位閥	FS-067S	●	●	●	●	●	●	●	●					32			
		FCD	16K	減壓閥	FS-065FK	●	●	●	●	●	●	●	●	●					33		
		FCD	16K	持壓閥	FS-066FK	●	●	●	●	●	●	●	●	●					34		
		FCD	16K	定水位閥	FS-067FK	●	●	●	●	●	●	●	●	●					35		
		FCD	16K	壓力調整閥	FS-068FK	●	●	●	●	●	●	●	●	●					36		
輔助資料	1.材料成份標準																	37			
	2.產品壓力溫度對照表																	38			
	3.橡膠耐高低溫範圍及材質特性																	39			
	4.配管注意事項																	40			
	5.法蘭規格表																	41			

FS-101

125S/200 W.O.G
黃銅閘門閥

BRASS GATE VALVE

總號：9805 類號：B2740

㊦第3581號

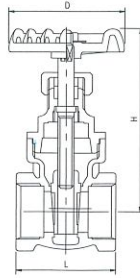

試壓	閥體	閥座
	17.0kg f/cm ² 水壓	13.0kg f/cm ² 水壓
	或 6kg/cm ² 空氣壓	或 6kg/cm ² 空氣壓

零件PART	材質MATERIAL	
閥體 BODY	CAST BRASS	YBSC3
閥蓋 BONNET	CAST BRASS	YBSC3
閥桿 STEM	BRASS	C3604B
閥盤 DISC	CAST BRASS	YBSC3
迫緊螺帽 P/N	BRASS	C3604B
迫緊 PACKING	GRAPHITE	COMMERCIAL
手輪 HANDWHEEL	ZINCALLOY	B86 ADC12

註: FS-101 CxC 套焊式

單位/mm

尺寸	1/4	3/8	1/2	3/4	1	1 1/4	1 1/2	2	2 1/2	3	4
L	41	41	43	47	53	60	62	72	89	101	116
H	71	71	73	83	94	114	123	148	183	210	248
D	54	54	54	54	61	77	77	83	105	112	132

FS-201

125S/200W.O.G
黃銅橫式逆止閥

BRASS SWING CHECK VALVE

總號：9804 類號：B2739

㊦第3845號

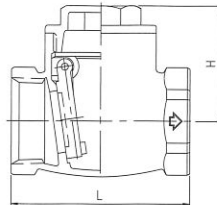

試壓	閥體	閥座
	17.0kg f/cm ² 水壓	13.0kg f/cm ² 水壓
	或 6kg/cm ² 空氣壓	或 6kg/cm ² 空氣壓

零件PART	材質MATERIAL	
閥體 BODY	CAST BRASS	YBSC3
閥蓋 BONNET	CAST BRASS	YBSC3
閥盤 DISC	CAST BRASS	C3771BE
堵頭 PLUG	BRASS	C3604B
銷 PIN	BRASS	C3604B

註: FS-201 CxC 套焊式

單位/mm

尺寸	1/2	3/4	1	1 1/4	1 1/2	2	2 1/2	3	4
L	54	60	70	82	89	110	135	151	185
H	37	39	44	50	55	66	83	94	110

FS-301

150S/600W.O.G
鍛造黃銅球塞閥

BRASS BALL VALVE

美國FM.U.L驗證通過

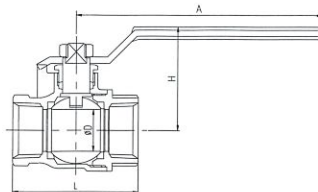

試壓	閥體	閥座
	63.0kg f/cm ² 水壓	63.0kg f/cm ² 水壓
	或 6kg/cm ² 空氣壓	或 6kg/cm ² 空氣壓

零件PART	材質MATERIAL	
閥體 BODY	FORGED BRASS	C3771BE(1/4"~2")
		YBSC3(2 1/2"~4")
迫緊壓蓋 PACKING CAP	BRASS	C3604B
迫緊 PACKING	PTFE	PTFE
閥桿 STEM	BRASS	C3604B
銅球 BALL	BRASS	C3771BE
把手 HANDWHEEL	STAINLESS STEEL	SUS304(1/4~1 1/2")
	DUCTILE	FCD

註: FS-301 CxC 套焊式

單位/mm

尺寸	1/4	3/8	1/2	3/4	1	1 1/4	1 1/2	2	2 1/2	3	4
L	43	46	54	63	76	85	92	108	131	150	159
H	32	37	38	47	52	60	65	75	85	94	94
D	9	10	12.7	19	25	32	38	50	63	75	75
A	80	80	80	110	110	130	130	200	200	200	200

* 2 1/2"-4" 標準壓力為400W.O.G

FS-103

125S/200W.O.G
鉑金銅閘門閥

BRONZE GATE VALVE

總號：11090 類號：B2765

㊟第4138號

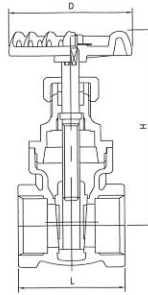

單位/mm

尺寸	1/2	3/4	1	1 1/4	1 1/2	2	2 1/2	3	4
L	42	48	52	59	63	72	89	101	116
H	73	83	95	114	123	148	183	210	260
D	54	54	61	77	77	83	105	112	132

試壓	閥體	閥座
	17.0kg f/cm ² 水壓 或 6kg/cm ² 空氣壓	13.0kg f/cm ² 水壓 或 6kg/cm ² 空氣壓

零件PART	材質MATERIAL	
閥體 BODY	CAST BRONZE	BC
閥蓋 BONNET	CAST BRONZE	BC
閥桿 STEM	BRASS	C3604B
閥盤 DISC	CAST BRONZE	BC
迫緊螺帽 P/N	BRASS	C3604B
迫緊 PACKING	GRAPHITE	NBR
手輪 HANDWHEEL	ZINCALLOY	B86 ADC12

FS-203

125S/200W.O.G
鉑金銅橫式逆止閥

BRONZE SWING CHECK VALVE

總號：11088 類號：B2763

㊟字第5556號

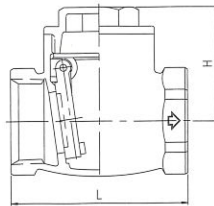

單位/mm

尺寸	1/2"	3/4"	1"	1 1/4"	1 1/2"	2"	2 1/2"	3"	4"
L	54	60	70	82	89	110	135	151	185
H	37	39	44	50	55	66	83	94	110

試壓	閥體	閥座
	17.0kg f/cm ² 水壓 或 6kg/cm ² 空氣壓	13.0kg f/cm ² 水壓 或 6kg/cm ² 空氣壓

零件PART	材質MATERIAL	
閥體 BODY	CAST BRONZE	BC
閥蓋 CAP	CAST BRONZE	BC
閥盤 DISC	CAST BRONZE	BC
堵頭 PULG	BRASS	C3604B
銷 PIN	BRASS	C3604B

FS-204

鉑金銅 125S/300W.O.G

BRONZE LIFT CHECK VALVE

FS-214

不銹鋼 無聲逆止閥

STAINLESS STEEL LIFT CHECK VALVE

不銹鋼固溶化熱處理CNS4000 G3092

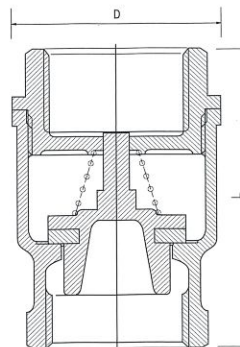

單位/mm

尺寸	1/2"	3/4"	1"	1 1/4"	1 1/2"	2"	2 1/2"	3"
D	32	39	48	57	67	81	108	126
L	53	59	67	78	84	98	115	130

試壓	閥體	閥座
	32.0kg f/cm ² 水壓 或 6kg/cm ² 空氣壓	24.0kg f/cm ² 水壓 或 6kg/cm ² 空氣壓

零件PART	FS-204	FS-214
閥體 BODY	CAST BRONZE	BC/316
閥蓋 CAP	CAST BRONZE	BC/316
閥盤 DISC	CAST BRONZE	BC/316
閥座 SEAT	EPDM	VITON
彈簧 SPRING	STAINLESS STEEL	304

FS-104

125S/300W.O.G
鈹金銅昇桿式閘門閥

BRONZE GATE VALVE Outside Screwed & yoke

符合CNS11089B2764

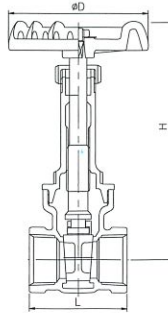

單位/mm

尺寸	1/2	3/4	1	1 1/4	1 1/2	2	2 1/2	3
L	50	51	60	68	72	83	102	116
H	107	122	152	174	199	235	282	326
D	65	70	83	92	92	112	127	150

試壓	閥體	閥座
	32.0kg f/cm ² 水壓	24.0kg f/cm ² 水壓
	或 6kg/cm ² 空氣壓	或 6kg/cm ² 空氣壓

零件PART	材質MATERIAL	
閥體 BODY	CAST BRONZE	BC
閥蓋 BONNET	CAST BRONZE	BC
閥桿 STEM	DZR	DZR
閥盤 DISC	CAST BRONZE	BC
迫緊螺帽 P/N	BRASS	C3604B
迫緊 PACKING	NEOPRENE	NEOPRENE
手輪 HANDWHEEL	CAST IRON	FC20

DZR:de-zincification resistant brass

FS-109

125S/300W.O.G
鈹金銅閘門閥

BRONZE GATE VALVE

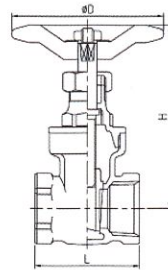

單位/mm

尺寸	1/2	3/4	1	1 1/4	1 1/2	2	2 1/2	3
L	50	51	60	68	72	83	102	116
H	76	86	106	123	138	164	197	224
D	65	70	83	92	92	112	127	150

試壓	閥體	閥座
	32.0kg f/cm ² 水壓	24.0kg f/cm ² 水壓
	或 6kg/cm ² 空氣壓	或 6kg/cm ² 空氣壓

零件PART	材質MATERIAL	
閥體 BODY	CAST BRONZE	BC
閥蓋 BONNET	CAST BRONZE	BC
閥桿 STEM	DZR	DZR
閥盤 DISC	CAST BRONZE	BC
迫緊螺帽 P/N	BRASS	C3604B
迫緊 PACKING	PTFE	PTFE
手輪 HANDWHEEL	CAST IRON	FC20

DZR:de-zincification resistant brass

FS-209

150S/300W.O.G
鈹金銅橫式逆止閥

BRONZE SWING CHECK VALVE

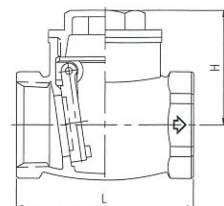

單位/mm

尺寸	1/2	3/4	1	1 1/4	1 1/2	2
L	54	61	70	81	91	109
H	37	41	47	57	62	69

註:2"以上, 標示 200W.O.G

試壓	閥體	閥座
	32.0kg f/cm ² 水壓	24.0kg f/cm ² 水壓
	或 6kg/cm ² 空氣壓	或 6kg/cm ² 空氣壓

零件PART	材質MATERIAL	
閥體 BODY	CAST BRONZE	BC
閥蓋 CAP	CAST BRONZE	BC
閥盤 DISC	CAST BRONZE	BC
堵頭 PULG	BRASS	C3604B
銷 PIN	BRASS	C3604B

FS-303

150S/600W.O.G
鉍金銅球塞閥

BRONZE BALL VALVE

總號：11355 類號：B2769

正 第8389

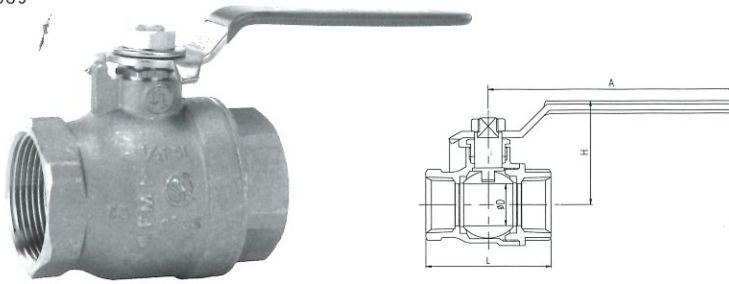

註:FS-301CxC 套焊式

單位/mm

尺寸	1/2	3/4	1	1 1/4	1 1/2	2	2 1/2	3
L	54	63	76	85	92	108	131	150
H	38	47	52	60	65	75	85	94
D	12.7	19	25	32	38	50	63	75
A	80	110	110	130	130	200	200	200

試壓	閥體	閥座
	63.0kg f/cm ² 水壓	63.0kg f/cm ² 水壓
	或 6kg/cm ² 空氣壓	或 6kg/cm ² 空氣壓

零件PART	材質MATERIAL	
閥體 BODY	CAST BRONZE	BC
迫緊壓蓋 PACKING CAP	BRASS	C3604B
迫緊 PACKING	PTFE	PTFE
閥桿 STEM	BRASS	C3604B
銅球 BALL	BRASS	C3771BE
把手 HANDWHEEL	STAINLESS STEEL	SUS304(1/2"~1 1/2")
	DUCTILE	FCD(2"~3")

FS-404

150S/300W.O.G
鉍金銅球型墊片閥

BRONZE GLOBE VALVE

銅系列

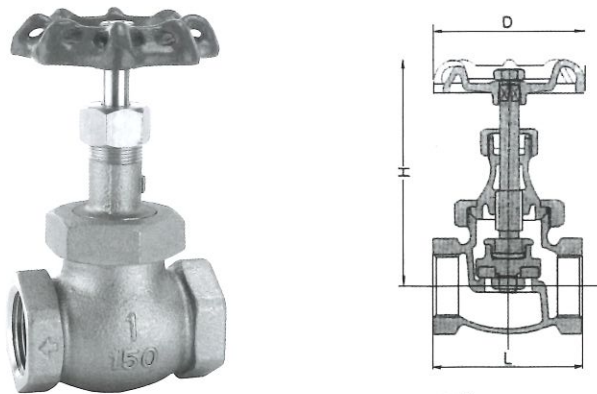

單位/mm

尺寸	1/2	3/4	1	1 1/4	1 1/2	2	2 1/2	3
L	56	66	76	88	101	121	145	160
H	102	115	137	148	168	198	232	258
D	62	65	75	85	95	105	125	135

試壓	閥體	閥座
	32.0kg f/cm ² 水壓	24.0kg f/cm ² 水壓
	或 6kg/cm ² 空氣壓	或 6kg/cm ² 空氣壓

零件PART	材質MATERIAL	
閥體 BODY	CAST BRONZE	BC
閥蓋 BONNET	CAST BRONZE	BC
閥桿 STEM	DZR	DZR
閥盤 DISC	PTFE 15%HGF	PTFE 15%HGF
閥座 DISC HOLDER	CAST BRONZE	BC
迫緊 PACKING	PTFE	PTFE
手輪 HANDWHEEL	CAST IRON	FC20

DZR:de-zincification resistant brass

FS-501 FS-511

鉍金銅
不銹鋼

減壓閥/組

PRESSURE REDUCING VALVE

不銹鋼固溶化熱處理CNS4000 G3092

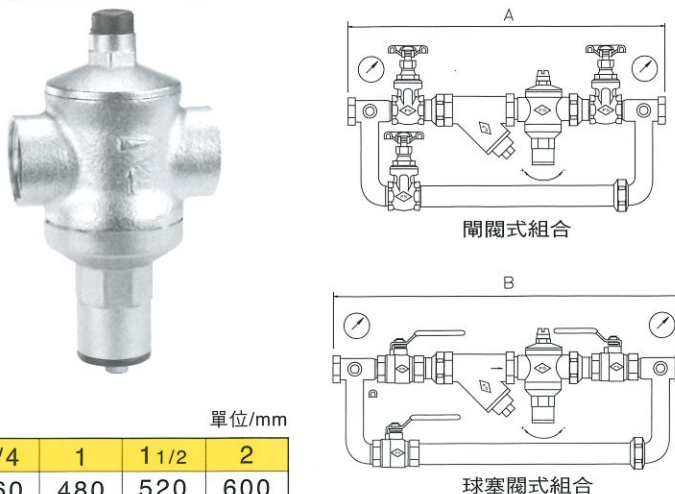

單位/mm

尺寸	3/4	1	1 1/2	2
A	460	480	520	600
B	460	480	520	600

適用壓力範圍			
閥體試壓	入口端 使用壓力	出口端 使用範圍	適用流體
24.0kg f/cm ²	10.0kg f/cm ²	0.5-0.3kg f/cm ²	常溫水

零件PART	FS-501	FS-511
閥體 BODY	CAST BRONZE	BC/SCS13
閥蓋 CAP	CAST BRONZE	SCS13
閥座 SEAT	NBR	NBR
活塞 PISTON	CAST BRASS	
彈簧 SPRING	304	304
封蓋 CAP	ABS	ABS

FS-601

自動釋氣閥

AIR VEN

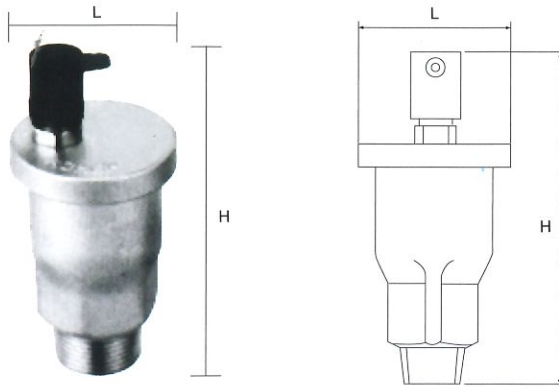

單位/mm

尺寸	1/2	3/4	1
L	47.6	47.6	47.6
H	103	103	103

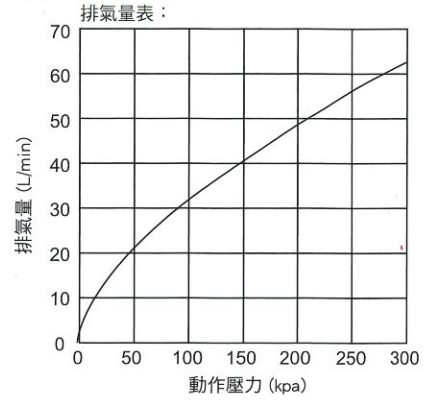

零件PART	材質MATERIAL	
閥體 BODY	FORGED BRASS	C3771BE
閥蓋 BONNET	FORGED BRASS	C3771BE
堵頭 PLUG	BRASS	C3604

FS-602 FS-612

鑄鐵 10K自動釋氣閥 不銹鋼 10K自動釋氣閥

CAST IRON AIR VEN STAINLESS STEEL AIR VEN

不銹鋼固溶化熱處理CNS4000 G3092

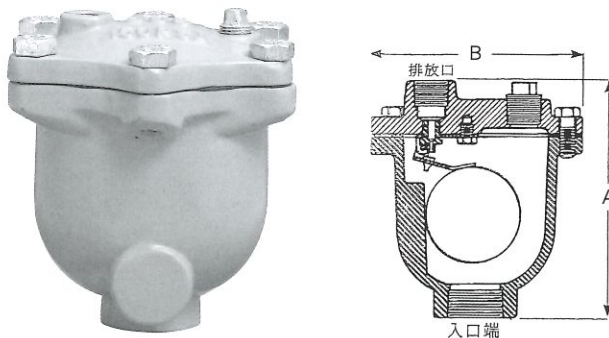

CF8 單位/mm

尺寸	1/2	3/4	1
A	133	133	133
B	121	121	121

FC 單位/mm

尺寸	1/2	3/4	1
A	130	130	130
B	115	115	115

零件PART	FS-602	FS-612
閥體 BODY	FC	CF8
閥蓋 CAP	FC	CF8
閥座 SEAT	SUS 304	SUS304
桿架 Lever Frome	SUS 304	SUS304
浮球 Float	SUS 304	SUS304
墊片 Gasket	NBR	
浮桿 Float Arm	SUS 304	SUS304
頂塞 Oritice Botton	NBR	

FS-701 FS-711

銅製品 不銹鋼

螺紋式 水錘吸收器

WATER HAMMER ARRESTERS

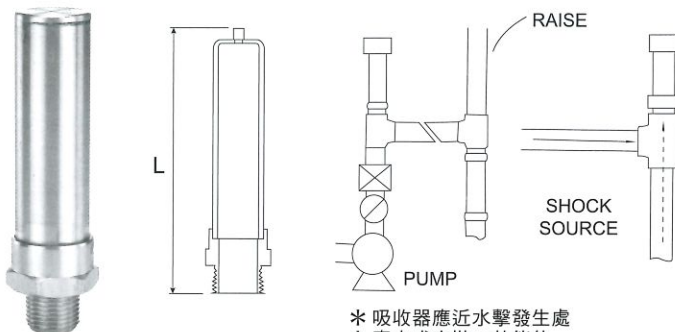

* 吸收器應近水擊發生處
* 直立式安裝，效能佳

註:FS-701 1/2"-2"外牙式 2 1/2"-3"內牙式

單位/mm

尺寸 L	1/2	3/4	1	1 1/4	1 1/2	2	2 1/2	3
FS-701	135	135	185	230	243	245	270	435
FS-711	143	143	211	240	271	280	-	-
注入壓力 (PSI)	20	20	25	25	30	30	30	35

* 1 1/2" (含)以上附氣嘴

零件 PART	FS-701	FS-711
閥體	K cooper	SUS 304
活塞	C 3604	SUS 304
O型環	NBR 食品級	NBR 食品級
氣嘴	C 3604	C 3604

	FS-701	FS-711
適用流體	水	水
最高壓力	120°C靜動水21kg/cm ² 120°C靜動水16kg/cm ²	120°C靜動水21kg/cm ² 120°C靜動水16kg/cm ²
適用溫度	0°C至80°C	0°C至80°C
測試壓力	450psi	450psi
一般操作壓力	300psi以下	300psi以下
材質	本體 Copper K TYPE 接口 JIS C3771/BC	304

FS-702 銅製品 10k **法蘭式**
FS-712 不銹鋼 10k **水錘吸收器**

WATER HAMMER ARRESTERS

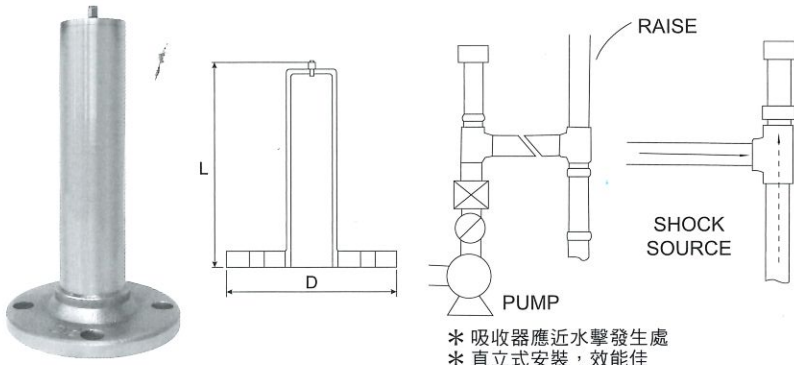

* 吸收器應近水擊發生處
 * 直立式安裝，效能佳

* 附氣嘴

單位/mm

尺寸 L	2 1/2	3	4	5	6	8
FS-702	325	415	415	505	630	780
FS-712	280	360	430	570	615	770
空氣壓 PSI	30	35	35	40	40	40

	FS-702	FS-712
閥體	K cooper	SUS 304
活塞	C 3604	SUS 304
O型環	NBR 食品級	NBR 食品級
氣嘴	C 3604	C 3604

	FS-702	FS-712
適用流體	水	水
最高壓力	120°C靜動水21kg/cm ² 120°C靜動水16kg/cm ²	120°C靜動水21kg/cm ² 120°C靜動水16kg/cm ²
適用溫度	0°C至80°C	0°C至80°C
測試壓力	450psi	450psi
一般操作壓力	300psi以下	300psi以下
材質	本體	Copper K TYPE
	接口	JIS C3771/BC
		304

FS-803 **150S/300W.O.G**
鉑金銅Y型過濾器

BRONZE Y-PATTERN STRAINER

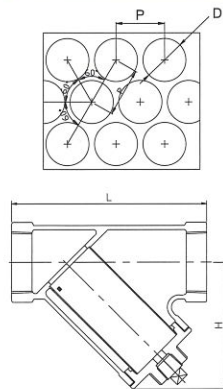

單位/mm

尺寸	1/2	3/4	1	1 1/4	1 1/2	2	2 1/2	3
L	80	100	115	135	160	190	229	264
H	60	70	75	90	102	128	132	146
D	1	1	1.5	1.5	2	2	2	2
P	2	2	2.5	2.5	3.5	3.5	3.5	3.5

試壓	閥體	閥座
	32.0kg t/cm ² 水壓	-
	或 6kg/cm ² 空氣壓	-

零件PART	材質MATERIAL	
閥體 BODY	CAST BRONZE	BC
閥蓋 CAP	CAST BRONZE	BC
過濾器 SCREEN	STAINLESS STEEL	SUS304
堵頭 PLUG	CAST BRONZE	BC1
墊片 GASRET	PTFE	PTFE

FS-020 **JIS-10K**
鉑金銅閘門閥

BRONZE GATE VALV FLANGE TYPE

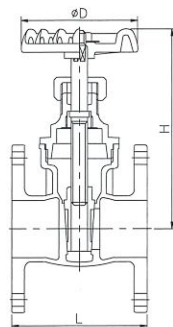

單位/mm

尺寸	2	2 1/2	3	4
L	115	128	142	165
H	145	190	223	260
D	85	105	120	130

試壓	閥體	閥座
	20.0kg t/cm ² 水壓	15.0kg t/cm ² 水壓
	或 6kg/cm ² 空氣壓	或 6kg/cm ² 空氣壓

零件PART	材質MATERIAL	
閥體 BODY	CAST BRONZE	BC
閥蓋 BONNET	CAST BRONZE	BC
閥盤 DISC	CAST BRONZE	BC
心桿 STEM	BRASS	C3604B
迫緊螺帽 P/N	BRASS	C3604B
心桿迫緊 PACKING	TEFLON	PTFE
手輪 HANDWHEEL	CAST IRON	FC20

FS-111

300PSI 不銹鋼閘門閥

STAINLESS STEEL GATE VALVES

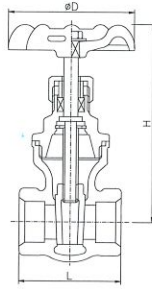

固溶化熱處理 CNS4000 G3092

單位/mm

尺寸	1/2	3/4	1	1 1/4	1 1/2	2	2 1/2
L	55	56	64.5	73	79	86.5	115
H	95	96	113	130	140	164	220
D	62	62	75	83	83	95	60

試壓	閥體	閥座
	42.0kg f/cm ² 水壓	32kg f/cm ² 水壓
	或 6kg/cm ² 空氣壓	或 6kg/cm ² 空氣壓

零件PART	材質MATERIAL	
閥體 BODY	STAINLESS STEEL	CF8M
閥蓋 BONNET	STAINLESS STEEL	CF8M
閥桿 STEM	STAINLESS STEEL	SUS316
閥盤 DISC	STAINLESS STEEL	CF8M
迫緊螺帽 P/N	STAINLESS STEEL	CF8M
迫緊 PACKING	PTFE	PTFE
手輪 HANDWHEEL	STAINLESS STEEL	SUS

FS-211

300PSI 不銹鋼逆止閥

STAINLESS STEEL SWING CHECK VALVES

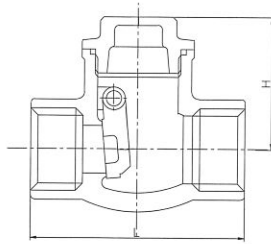

固溶化熱處理 CNS4000 G3092

單位/mm

尺寸	1/2	3/4	1	1 1/4	1 1/2	2
L	60	78	84	94	104	122
H	41.5	46	49	53.5	58.5	67

試壓	閥體	閥座
	42.0kg f/cm ² 水壓	32kg f/cm ² 水壓
	或 6kg/cm ² 空氣壓	或 6kg/cm ² 空氣壓

零件PART	材質MATERIAL	
閥體 BODY	STAINLESS STEEL	CF8M
閥蓋 BONNET	STAINLESS STEEL	CF8M
閥盤 DISC	STAINLESS STEEL	CF8M
堵頭 PLUG	STAINLESS STEEL	SUS 316
銷 P/N	STAINLESS STEEL	SUS 316

FS-411

300PSI 不銹鋼Y型墊片球型閥

STAINLESS STEEL GLOBE VALVES

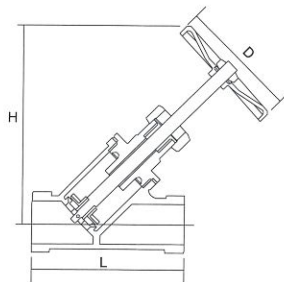

固溶化熱處理 CNS4000 G3092

單位/mm

尺寸	1/2	3/4	1	1 1/4	1 1/2	2
L	61	70	86	100	111	138
H	100	125	130	165	195	210
D	62	62	75	75	95	95

試壓	閥體	閥座
	42.0kg f/cm ² 水壓	32kg f/cm ² 水壓
	或 6kg/cm ² 空氣壓	或 6kg/cm ² 空氣壓

零件PART	材質MATERIAL	
閥體 BODY	STAINLESS STEEL	CF8M
閥蓋 BONNET	STAINLESS STEEL	CF8M
閥桿 STEM	STAINLESS STEEL	SUS316
閥盤 DISC	STAINLESS STEEL	CF8M
迫緊螺帽 P/N	STAINLESS STEEL	SUS304
迫緊 PACKING	PTFE	PTFE
手輪 HANDWHEEL	CAST IRON	FC20

FS-311

1000W.O.G
不銹鋼球塞閥

ONE PIECE STAINLESS STEEL BALL VALVES

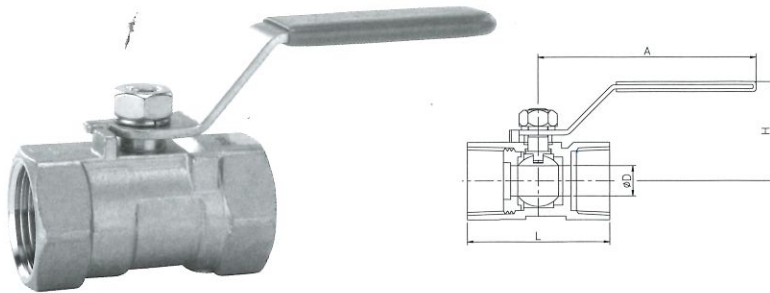

固溶化熱處理 CNS4000 G3092

註：倘應用於150°C以上之工作溫度，需另行更換球墊

單位/mm

尺寸	1/4	3/8	1/2	3/4	1	1 1/4	1 1/2	2
D	5	7	9.2	12.5	15	20	25	32
L	39	44	56	59	71	77	83	100
H	33	35	42	46	50	56	66	72
A	68	79	90	90	104	104	126	126

試壓	閥體	閥座
	42.0kg f/cm ² 水壓	32kg f/cm ² 水壓
	或 6kg/cm ² 空氣壓	或 6kg/cm ² 空氣壓

零件PART	材質MATERIAL	
閥體 BODY	STAINLESS STEEL	CF8M
閥蓋 BONNET	STAINLESS STEEL	CF8M
閥桿 STEM	STAINLESS STEEL	SUS 316
閥球 BALL	STAINLESS STEEL	CF8M
球墊 BALL SEAT	PTFE	PTFE
把手 HANDLE	STAINLESS STEEL	304

FS-312

1000W.O.G
不銹鋼球塞閥

TWO PIECE STAINLESS STEEL BALL VALVES

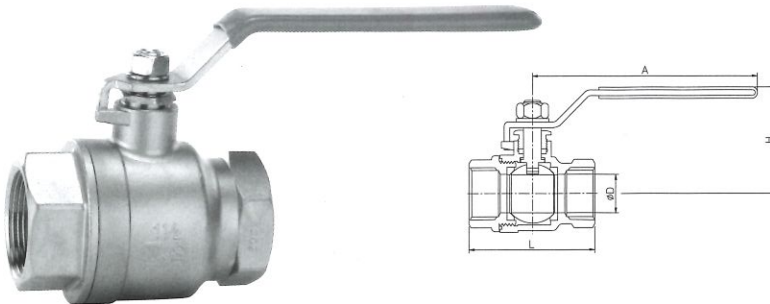

固溶化熱處理 CNS4000 G3092

註：倘應用於150°C以上之工作溫度，需另行更換球墊

單位/mm

尺寸	1/4	3/8	1/2	3/4	1	1 1/4	1 1/2	2	2 1/2	3
D	11.6	12.5	15	20	25	32	38	50	65	80
L	54.3	54.3	65	76	89	101.5	113	124	159.3	175.3
H	50	50	60	62	73	80	90	100	128	137
A	108	108	133	133	153	153	190	190	247	247

試壓	閥體	閥座
	42.0kg f/cm ² 水壓	32kg f/cm ² 水壓
	或 6kg/cm ² 空氣壓	或 6kg/cm ² 空氣壓

零件PART	材質MATERIAL	
閥體 BODY	STAINLESS STEEL	CF8M
閥蓋 BONNET	STAINLESS STEEL	CF8M
閥桿 STEM	STAINLESS STEEL	SUS 316
閥球 BALL	STAINLESS STEEL	CF8M
球墊 BALL SEAT	PTFE	PTFE
把手 HANDLE	STAINLESS STEEL	SUS 304

FS-313

1000W.O.G
不銹鋼球塞閥

THREE PIECE STAINLESS STEEL BALL VALVES

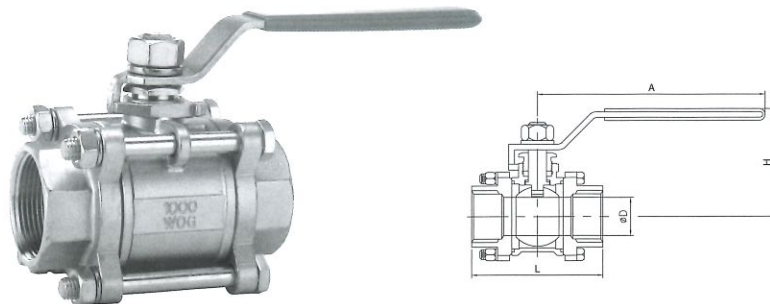

固溶化熱處理 CNS4000 G3092

註1：套焊式FS-313S，對焊式FS-313B

註2：倘應用於150°C以上之工作溫度，需另行更換球墊

單位/mm

尺寸	1/4	3/8	1/2	3/4	1	1 1/4	1 1/2	2	2 1/2	3	4
D	11.6	12.5	15	20	25	32	38	50	65	80	100
L	59	59	69	78	84	104	119	131	162	182	230
H	54	54	55	59	70	75	84	92	128	137	173
A	103	103	133	133	153	153	191	191	247	247	295

試壓	閥體	閥座
	42.0kg f/cm ² 水壓	32kg f/cm ² 水壓
	或 6kg/cm ² 空氣壓	或 6kg/cm ² 空氣壓

零件PART	材質MATERIAL	
閥體 BODY	STAINLESS STEEL	CF8M
閥蓋 BONNET	STAINLESS STEEL	CF8M
閥桿 STEM	STAINLESS STEEL	SUS 316
閥球 BALL	STAINLESS STEEL	CF8M
球墊 BALL SEAT	PTFE	PTFE
把手 HANDLE	STAINLESS STEEL	SUS 304
螺栓 BOLT	STAINLESS STEEL	SUS 304
螺帽 NUT	STAINLESS STEEL	SUS 304

FS-030
FS-030A

JIS-10K
ANSI-150

不銹鋼球塞閥

TWO PIECE STAINLESS STEEL BALL VALVES

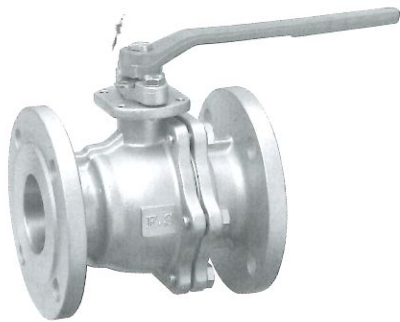

Face To Face:ANSI B 16. 10
End Flanges:ANSI B 16.5(150#)
:JIS B2238(10K)
Shell wall thickness:ANSI B 16.34

註1. 8"及以上為齒輪操作。
註2. 可依客戶使用需求，加裝齒輪箱操作，減輕操作扭力。
註3. 也可依使用需求，訂製禁油品，並加掛標籤。
註4. 可依使用需求，加裝防靜電裝置。
註5. 316材質:FS-030M
註6. JIS-16K產品，編號FS-030K

固溶化熱處理 CNS4000 G3092

單位/mm

尺寸	1/2"	3/4"	1"	1 1/4"	1 1/2"	2"	2 1/2"	3"	4"	5"	6"	8"	10"	12"
L	110	120	130	140	165	180	190	200	230	300(10K) 356(150#)	340(10K) 394(150#)	450	530	620
H	84	84	84	91	115	120	140	153	171	227	230	297	340	382
D	15	20	25	65	40	50	64	80	100	125	150	200	250	300
A	175	175	175	175	230	230	340	340	340	700	700	700	800	950

最高使用壓力	試驗壓力(水壓)	
	閥體	閥座
請參閱溫度/壓力基準表 Lest pressure:ANSI B16.34	20kg f/cm ² 或 空氣壓6kg f/cm ²	15kg f/cm ² 或 空氣壓6kg f/cm ²

零件PART	材質MATERIAL	
閥體 BODY	STAINLESS STEEL	CF8
閥蓋 BODY CAP	STAINLESS STEEL	CF8
閥球迫緊 SEAT	TEFLON	PTFE
閥球 BALL	STAINLESS STEEL	CF8
閥桿 STEM	STAINLESS STEEL	SUS304
把手 HANDLE	DUCTILE IRON	FCD45
壓板 GLAND FLANGED	STAINLESS STEEL	SUS304
定位片 TRAVEL STOPPER	STAINLESS STEEL	SUS304
齒輪箱 GEAR BOX	CAST IRON	FC20

FS-313L

1000W.O.G
加長對焊不銹鋼球塞閥

THREE PIECE STAINLESS STEEL BALL VALVES

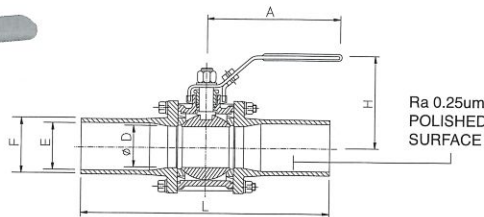

固溶化熱處理 CNS4000 G3092

單位/mm

尺寸	3/8	1/2	3/4	1	1 1/4	1 1/2	2	2 1/2	3
D	12.7	15	20	25	32	38	50	65	80
L	120	170	178	210	220	230	245	265	290
H	49	60	62	75	82	110	120	130	150
A	100	100	120	148	148	164	164	248	248
F	17.3	21.7	27.2	34	42.7	48.6	60.5	76.3	89.1
E(SCH5)	14.9	18.4	23.9	30.7	39.4	45.3	57.2	72.1	84.9
E(SCH10)	14	17.5	23	28.4	37.1	43	54.9	70.3	83.1

試壓	閥體	閥座
	42.0kg f/cm ² 水壓 或 6kg/cm ² 空氣壓	32kg f/cm ² 水壓 或 6kg/cm ² 空氣壓

零件PART	材質MATERIAL	
閥體 BODY	STAINLESS STEEL	CF8M
閥蓋 BONNET	STAINLESS STEEL	CF8M
閥桿 STEM	STAINLESS STEEL	SUS 316
閥球 BALL	STAINLESS STEEL	CF8M
球墊 BALL SEAT	PTFE/RPTFE	PTFE/RPTFE
把手 HANDLE	STAINLESS STEEL	SUS 304
螺栓 BOLT	STAINLESS STEEL	SUS 304
螺帽 NUT	STAINLESS STEEL	SUS 304

FS-811

150S/300W.O.G
不銹鋼Y型過濾器

STAINLESS STEEL Y-STRAINER

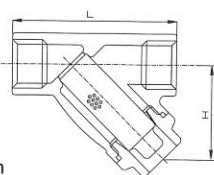
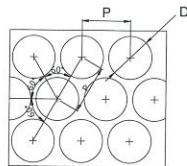

固溶化熱處理 CNS4000 G3092

單位/mm

尺寸	1/2	3/4	1	1 1/4	1 1/2	2
L	61	70	86	100	111	138
H	37	41	47	54	62	76
D	1	1	1.5	1.5	2	2
P	2	2	2.5	2.5	3.5	3.5

試壓	閥體	閥座
	42.0kg f/cm ² 水壓 或 6kg/cm ² 空氣壓	—

零件PART	材質MATERIAL	
閥體 BODY	STAINLESS STEEL	CF8M
閥蓋 BONNET	STAINLESS STEEL	CF8M
過濾網 SCREEN	STAINLESS STEEL	SUS316
墊片 GASKET	PTFE	PTFE

不銹鋼系列

FS-031

JIS-10K 不銹鋼昇桿式閘門閥

STAINLESS STEEL GATE VALVES Outside screw and yoke

固溶化熱處理 CNS4000 G3092

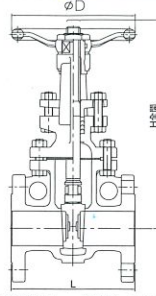
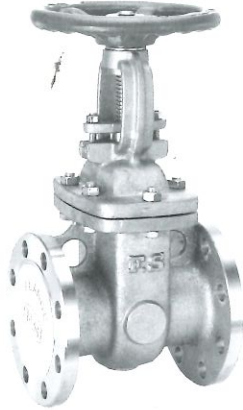

註1: 316材質製品, 編號 FS-031M
 註2: JIS-16K產品, 編號 FS-031K
 JIS-20K產品, 編號 FS-031DK
 註3: 可訂製禁油品
 註4: 316材質製品, 150PSI, 編號 FS-031MA
 註5: 304材質製品, 150PSI, 編號 FS-031A
 單位/mm

尺寸	2	2 1/2	3	4	5	6	8	10	12	14
L	178	190	203	229	254	267	292	330	356	381
H	340	398	490	577	695	770	990	1115	1385	1600
D	170	170	189	222	290	290	350	400	400	500

最高使用壓力	試驗壓力(水壓)	
	閥體	閥座
請參閱溫度/壓力基準表	20kg f/cm ² 或 空氣壓6kg f/cm ²	15kg f/cm ² 或 空氣壓6kg f/cm ²

零件PART	材質MATERIAL	
閥體 BODY	STAINLESS STEEL	SCS13/SCS14
閥蓋 BONNET	STAINLESS STEEL	SCS13/SCS14
閥桿 STEM	STAINLESS STEEL	SUS304
閥盤 DISC	STAINLESS STEEL	SCS13
手輪 HANDWHEEL	DUCTILE IRON / STAINLESS	FCD45 / SUS
壓板 GLAND	STAINLESS STEEL	SCS13
迫緊 PACKING	TEFLON	PTFE

不銹鋼系列

FS-032

JIS-10K 不銹鋼橫式逆止閥

STAINLESS STEEL SWING CHECK VALVES

固溶化熱處理 CNS4000 G3092

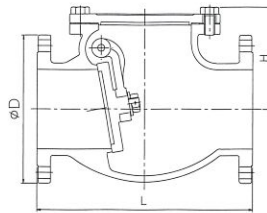

註1: 316材質產品, 編號 FS-032M
 註2: JIS-16K產品, 編號 FS-032K
 JIS-20K產品, 編號 FS-032DK
 註3: 可訂製禁油品
 單位/mm

尺寸	2	2 1/2	3	4	5	6	8	10	12
L	203	216	240	292	330	356	495	622	699
H	102	120	125	168	178	200	235	350	380
D	155	175	185	210	250	280	330	400	445

最高使用壓力	試驗壓力(水壓)	
	閥體	閥座
請參閱溫度/壓力基準表	20kg f/cm ² 或 空氣壓6kg f/cm ²	15kg f/cm ² 或 空氣壓6kg f/cm ²

零件PART	材質MATERIAL	
閥體 BODY	STAINLESS STEEL	SCS13/SCS14
閥蓋 BONNET	STAINLESS STEEL	SCS13/SCS14
閥座 DISC	STAINLESS STEEL	SCS13/SCS14
閥環 SEAT RING	STAINLESS STEEL	SCS13/SCS14
固定軸 HIGH PIN	STAINLESS STEEL	SUS304
閥座插銷 P/N	STAINLESS STEEL	SUS304
塞頭 PLUG	STAINLESS STEEL	SUS304
墊片 GASKET	TEFLON	PTFE

FS-033

JIS-10K 不銹鋼Y型過濾器

STAINLESS STEEL Y-STRAINER

固溶化熱處理 CNS4000 G3092

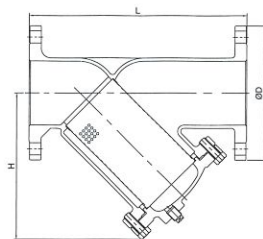

註1: 316材質製品, 編號 FS-033M
 註2: JIS-16K產品, 編號 FS-033K
 JIS-20K產品, 編號 FS-033DK
 註3: 可訂製禁油品
 單位/mm

尺寸	2	2 1/2	3	4	5	6	8	10	12
L	220	270	290	350	390	440	540	680	780
H	140	175	196	244	277	320	390	485	580
D	155	175	185	210	250	280	330	400	445

最高使用壓力	試驗壓力(水壓)	
	閥體	閥座
請參閱溫度/壓力基準表	20kg f/cm ² 或 空氣壓6kg f/cm ²	15kg f/cm ² 或 空氣壓6kg f/cm ²

零件PART	材質MATERIAL	
閥體 BODY	STAINLESS STEEL	SCS13/SCS14
閥蓋 COVER	STAINLESS STEEL	SCS13/SCS14
過濾網 SCREEN	STAINLESS STEEL	SUS304
墊片 GASKET	TEFLON	PTFE
塞頭 PLUG	STAINLESS STEEL	SUS304

FS-034

JIS-10K 不銹鋼球型閥

STAINLESS STEEL GLOBE VALVES

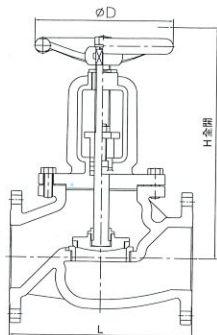

固溶化熱處理 CNS4000 G3092
註1:316材質製品，編號 FS-034M
註2:可訂製禁油品

單位/mm

尺寸	2	2 1/2	3	4	5	6	8	10	12
L	203	216	241	292	356	406	495	622	698
H	270	290	320	350	410	520	570	670	736
D	180	180	200	230	250	280	290	330	350

最高使用壓力	試驗壓力(水壓)	
	閥體	閥座
請參閱溫度/壓力基準表	20kg f/cm ² 或 空氣壓6kg f/cm ²	15kg f/cm ² 或 空氣壓6kg f/cm ²

零件PART	材質MATERIAL	
閥體 BODY	STAINLESS STEEL	SCS13/SCS14
閥蓋 BONNET	STAINLESS STEEL	SCS13/SCS14
閥座 DISC	STAINLESS STEEL	SCS13/SCS14
手輪 HANDWHEEL	DUCTILE IRON	FCD45
壓板 GLAND	STAINLESS STEEL	SCS13/SCS14
閥桿 STEM	STAINLESS STEEL	SUS304
迫緊 PACKING	TEFLON	PTFE

FS-035

JIS-10K 不銹鋼拉柄式底閥

STAINLESS STEEL FOUT VELVES

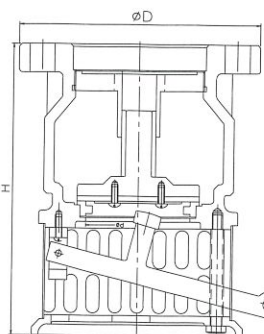

固溶化熱處理 CNS4000 G3092
註1:JIS-16K產品，編號 FS-035K

單位/mm

尺寸	2	2 1/2	3	4	5	6	8	10	12
H	179	186	218	224	253	271	393	420	475
D	155	175	185	210	250	280	330	400	445

最高使用壓力	試驗壓力(水壓)	
	閥體	閥座
常溫脈動水		
10.0kg f/cm ²	20.0kg f/cm ²	15.0kg f/cm ²

零件PART	材質MATERIAL	
閥體 BODY	STAINLESS STEEL	SCS13/SCS14
閥盤 DISC	STAINLESS STEEL	SCS13/SCS14
座環 SEAT RING	STAINLESS STEEL	SCS13/SCS14
閥座橡皮 DISC SEAT	NBR/EPDM	NBR/EPDM
閥座墊圈 GASKET	STAINLESS STEEL	SUS304
底盤套管 TUBE	STAINLESS STEEL	SUS304
洗桿 LEVER	STAINLESS STEEL	SCS13

FS-040

JIS-10K 不銹鋼無聲逆止閥

STAINLESS STEEL SILENT CHECK VALVES

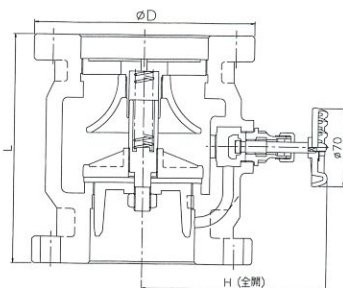

固溶化熱處理 CNS4000 G3092
註1:JIS-16K製品，編號 FS-040K

單位/mm

尺寸	2	2 1/2	3	4	5	6	8	10	12
L	187	200	210	218	255	279	415	555	615
H	163	173	180	190	210	225	245	285	310
D	155	175	185	210	250	280	330	400	445

最高使用壓力		試驗壓力(水壓)	
80°C以下 之靜流水	80°C以下 之脈動水	閥體	閥座
14.0kg f/cm ²	10.0kg f/cm ²	20.0kg f/cm ²	15.0kg f/cm ²

零件PART	材質MATERIAL	
閥體 BODY	STAINLESS STEEL	SCS13/SCS14
閥盤 DISC	STAINLESS STEEL	SCS13/SCS14
軸心 SPINDLE	STAINLESS STEEL	SCS13/SCS14
閥座橡皮 RUBBER SEAT	NBR/EPDM	
止水座 GUIDE	STAINLESS STEEL	SCS13/SCS14
彈簧 SPRING	STAINLESS STEEL	SUS304
傘形緩衝器	STAINLESS STEEL	SCS13/SCS14

FS-037

JIS-10K 不銹鋼蝶型閥

STAINLESS STEEL BUTTERFLY VALVE

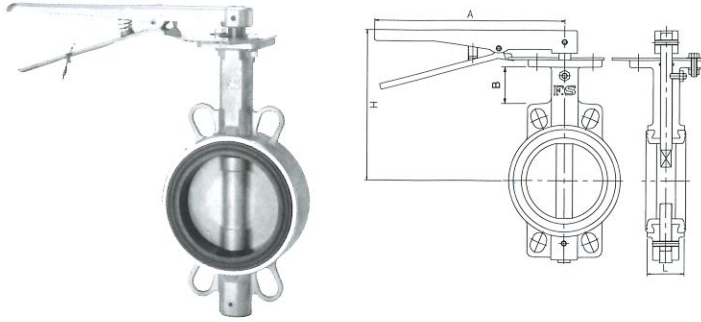

固溶化熱處理 CNS4000 G3092
 註1:316材質產品，編號 FS-037M
 註2:JIS-16K產品，編號 FS-037K

單位/mm

尺寸	2	2 1/2	3	4	5	6	8	10	12
L	43	46	46	52	56	56	60	68	78
H	145	158	167	192	206	221	262	310	334
A	220	220	220	245	245	245	360	360	360

最高使用壓力		試驗壓力(水壓)	
80°C以下之靜流水	80°C以下之脈動水	閥體	閥座
10.0kg f/cm ²	10.0kg f/cm ²	15.0kg f/cm ²	11kg f/cm ²

零件PART	材質MATERIAL	
閥體 BODY	STAINLESS STEEL	CF8M/CF8
閥座 SEAT	NBR / EPDM / VITON	
擋流盤 DISC	STAINLESS STEEL	SCS14/SCS13
閥桿 STEM	STAINLESS STEEL	SUS304
O形環 O-RING	NBR	
彈簧 SPRING	STAINLESS STEEL	SUS304
固定片 PLATE	STAINLESS STEEL	SCS14/SCS13
把手 HANDLE	STAINLESS STEEL	SCS14/SCS13

不銹鋼系列

FS-038

JIS-10K 不銹鋼齒輪式蝶型閥

STAINLESS STEEL BUTTERFLY VALVE

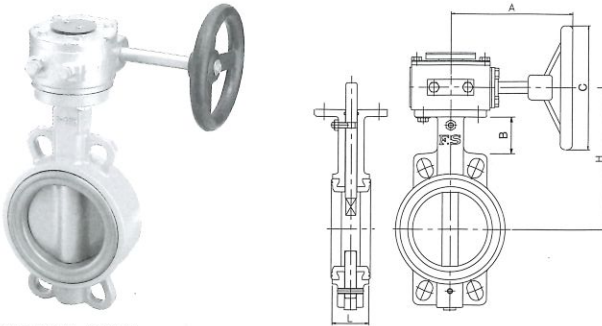

固溶化熱處理 CNS4000 G3092
 註1:316材質產品，編號 FS-038M
 註2:JIS-16K產品，編號 FS-038K

單位/mm

尺寸	2	2 1/2	3	4	5	6	8	10	12	14	16	18	20	24
L	43	46	46	52	56	56	60	68	78	78	102	114	127	154
H	145	158	167	192	206	221	263	311	335	398	423	483	503	568
A	165	165	165	165	165	165	270	270	270	280	280	280	300	300
C	140	140	140	140	140	140	250	250	250	350	350	350	410	410

最高使用壓力		試驗壓力(水壓)	
80°C以下之靜流水	80°C以下之脈動水	閥體	閥座
10.0kg f/cm ²	10.0kg f/cm ²	15.0kg f/cm ²	11kg f/cm ²

零件PART	材質MATERIAL	
閥體 BODY	STAINLESS STEEL	CF8M/CF8
閥座 SEAT	NBR / EPDM / VITON	
擋流盤 DISC	STAINLESS STEEL	SCS14/SCS13
閥桿 STEM	STAINLESS STEEL	SUS304
O形環 O-RING	NBR	
彈簧 SPRING	STAINLESS STEEL	SUS304
齒輪操作器 GEAR BOX	STAINLESS STEEL	SCS13

FS-039

JIS-10K 不銹鋼雙瓣式逆止閥

STAINLESS STEEL WAFER TYPE CHECK VALVES

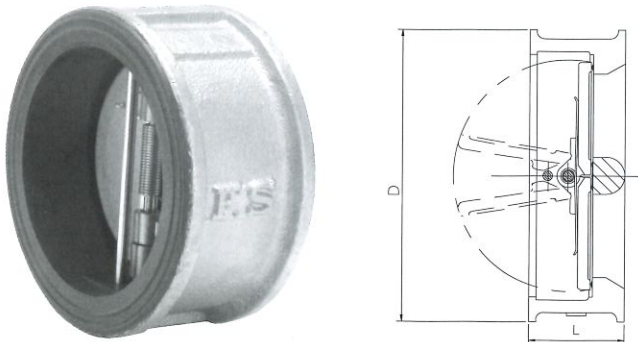

固溶化熱處理 CNS4000 G3092
 註1:316材質產品，編號 FS-039M
 註2:JIS-16K產品，編號 FS-039K
 註3:12"以上可接受訂製

單位/mm

尺寸	2	2 1/2	3	4	5	6	8	10	12
L	54	54	57	64	70	76	95	108	143
D	101	121	131	156	187	217	267	330	375

最高使用壓力		試驗壓力(水壓)	
80°C以下之靜流水	80°C以下之脈動水	閥體	閥座
10.0kg f/cm ²	10.0kg f/cm ²	20.0kg f/cm ²	15.0kg f/cm ²

零件PART	材質MATERIAL	
閥體 BODY	STAINLESS STEEL	SCS14/SCS13
閥盤 DISC	STAINLESS STEEL	SCS14/SCS13
閥座 SEAT	NBR / EPDM / VITON	
彈簧 SPRING	STAINLESS STEEL	SUS316
鉸鏈銷 HINGE PIN	STAINLESS STEEL	SUS304
停止銷 STOP PIN	STAINLESS STEEL	SUS304
塞頭 PLUG	STAINLESS STEEL	SUS304
墊片 WASHER	TEFLON	PTFE

FS-041	FCD葉片	把手型蝶閥
FS-043	304葉片	
FS-042	FCD葉片	齒輪型蝶閥
FS-044	304葉片	

CAST IRON BUTTERFLY VALVE & LEVER

CAST IRON BUTTERFLY VALVE & GEAR

Flanges: JIS B2212 10K
ANSI B16.1 class 125
ANSI B16.5 class 150

FACE TO FACE: ISO 5752
MOUNTING PAD: ISO 5211 TABLE 5.
TEST INSPECTION: ISO 5208 API-598
DESIGN STANDARD: API-609
TEST PRESSURE: Body 20kg/cm²
: Seat 12kg/cm²

註:閥體採環氧樹脂塗裝, 厚度125±25 Micron

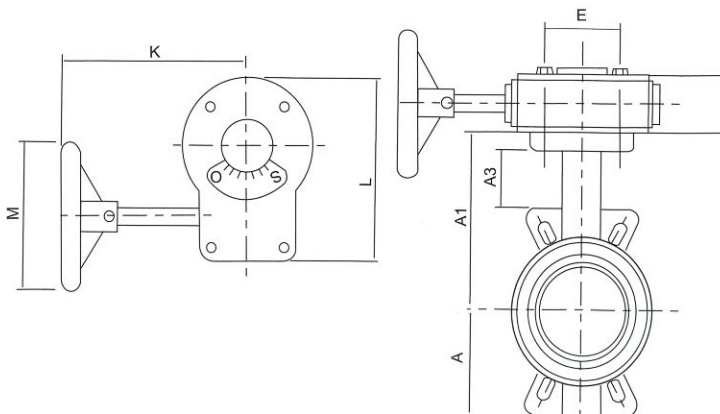
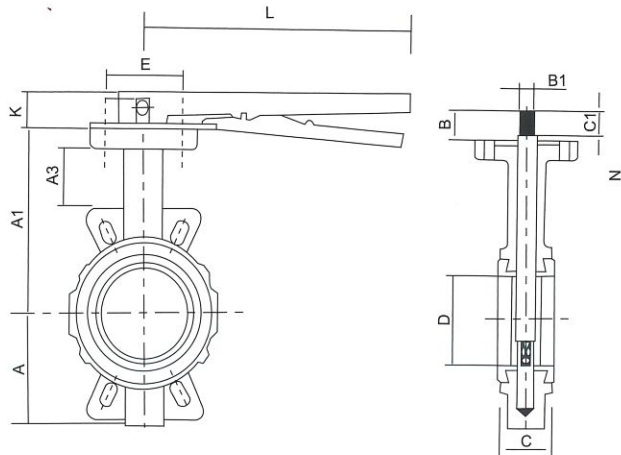
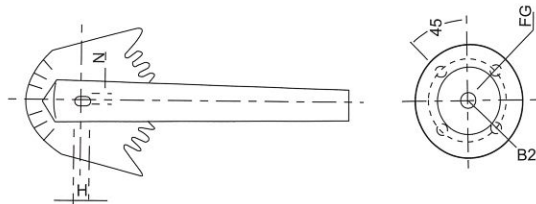
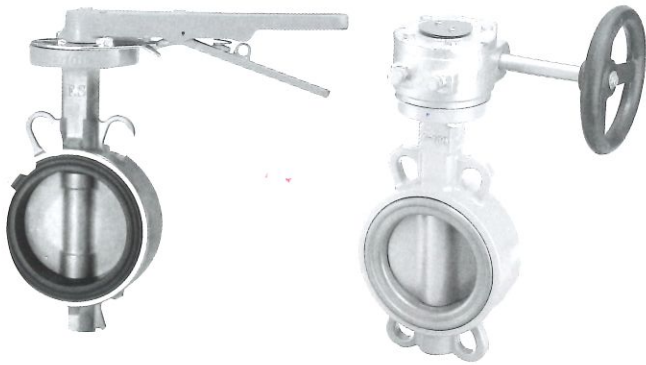

零件PART	材質MATERIAL		可變更材質
閥體 BODY	FC20	A126	FCD/WCB
閥座 SEAT	NBR(80°C)/EPDM(120°C)		VITON
閥桿 STEM	SUS410		304/316
葉片 ⁰⁴¹ / ₀₄₂ DISC	FCD45	A536	AL Bronze
葉片 ⁰⁴³ / ₀₄₄ DISC	SCS13	A351 CF8	SCS14
固定片 BUSHING	NYLON		SS41
O形環 O-RING	NBR		
把手 LEVER	FCD45	A536	
齒輪操作器 GEAR BOX	FC20	A126 B	

LALVE SIZE	LEVER OPERATED DIMENSIONS			
inch	K	L	M	N
2-3	30	220	8	13
4-5	30	245	11	16
6	30	245	13	19
8	34	360	16	22
10	34	360	19	25
12	34	360	19	28

SIZE	A	A1	B	B1	B2	C	C1	D	E	A3
2"	75	142	32	13	8	43	24	53	70	83
2.5"	78	147	32	13	8	46	24	70	70	88
3"	85	155	32	13	8	46	24	81	70	40
4"	110	170	32	16	11	52	24	103	70	45
5"	125	175	32	16	11	56	24	126	70	50
6"	140	185	32	19	13	56	24	149	70	50
8"	160	225	34	22	16	60	26	193	102	45
10"	205	280	34	25	19	68	26	245	102	40
12"	238	300	34	30	19	78	26	296	102	45

LALVE SIZE	HANDWHEEL GEAR ACTUATOR			
inch	K	L	M	N
2-6	165	110	140	60
8-12	270	162	245	70
14-18	280	213	350	85
20-24	300	283	410	105

SIZE	A	A1	B	B1	B2	C	C1	D	E	A3
2"	75	142	32	13	8	43	24	56	70	89
2.5"	78	147	32	13	8	46	24	70	70	88
3"	85	155	32	13	8	46	24	81	70	40
4"	110	170	32	16	11	52	24	103	70	45
5"	125	175	32	16	11	56	24	126	70	50
6"	140	185	32	19	13	56	24	149	70	50
8"	160	225	34	22	16	60	26	193	102	45
10"	205	280	34	25	19	68	26	245	102	40
12"	238	300	34	30	19	78	26	296	102	45
14"	266	355	55	35	10*8	78	40	330	140	70
16"	300	380	55	42	10*8	102	40	386	140	75
18"	323	425	55	45	10*8	114	40	433	140	75
20"	350	430	90	50	12*8	127	40	487	165	77
22"	380	490	90	50	12*8	154	40	536	180	80
24"	407	500	90	60	12*8	154	40	582	180	80

FS-045 鑄鐵全耳型 把手式蝶型閥

CAST IRON LUG TYPE BUTTERFLY VALVE & LEVER

FS-046 鑄鐵全耳型 齒輪式蝶型閥

CAST IRON LUG TYPE BUTTERFLY VALVE & GEAR

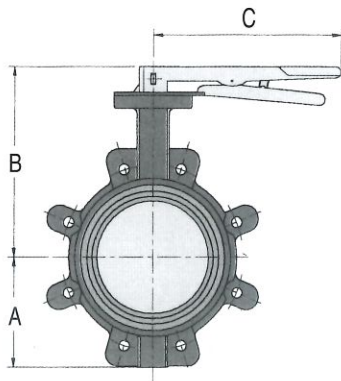
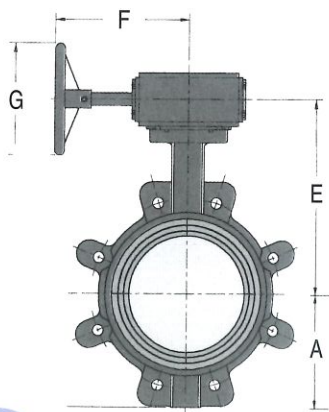
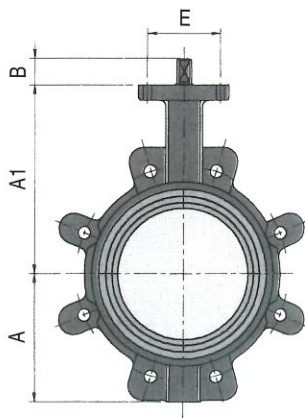
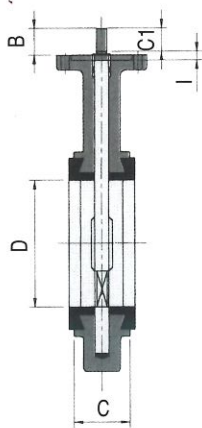
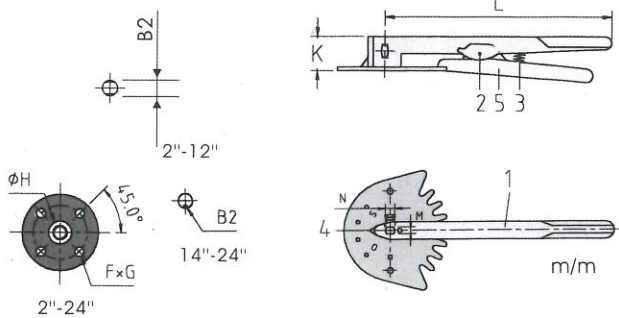
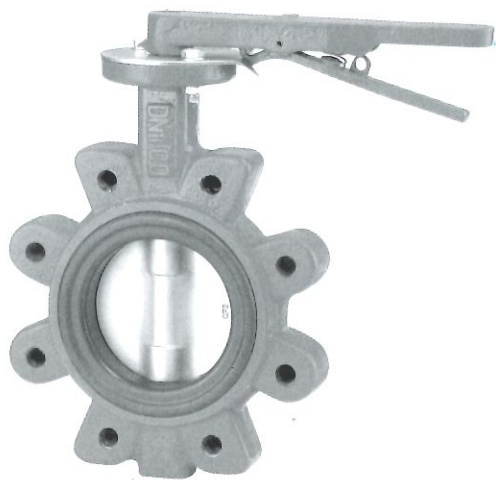

零件PART		材質MATERIAL		可變更材質
閥體	BODY	CAST IRON	A126	FCD.SCS13 / 14
閥座	SEAT	NBR/EDDM		VITON
閥桿	STEM	STAINLESS STELL	SCS 304	SCS410 / 316
葉片	DISC	STAINLESS STELL	SCS 13	SCS 14/FCD
固定片	BUSHING	NYLON	SS41	
把手	LEVER	DUCTILE IRON	FCD45	SCS 13
齒輪操作器	GEAR BOX	CAST IRON	FC20	

NO. Name	Material	LEVER OPERATED DIMENSIONS				
		inch	K	L	M	N
1.Handle	FCD 45	2-3	30	220	8	13
2.Spring Pin	SK 5	4-6	30	245	11	16
3.Spring	SUP 3	8	34	360	13	19
4.Lock Plate	SS 41	10	34	360	16	22
5.Lock Handle	SS 41	12	34	360	19	28

VALVE SIZE		DIMENSIONS(m/m)										
m/m	inch	A	A1	B	B1	B2	C	C1	D	E	FxG	H
50	2"	85	135	32	13	8	43	24	56	70	10x4	55
65	2 1/2"	90	145	32	13	8	46	24	70	70	10x4	55
80	3"	98	152	32	13	8	46	24	81	70	10x4	55
100	4"	112	170	32	16	11	52	24	103	70	10x4	55
125	5"	125	187	32	16	11	56	24	126	70	10x4	55
150	6"	140	200	32	16	11	56	24	149	70	10x4	55
200	8"	170	230	34	19	13	60	26	193	102	12x4	70
250	10"	207	276	34	22	16	68	26	245	102	12x4	70
300	12"	238	300	34	28	19	78	26	296	102	12x4	70
350	14"	266	355	55	32	10x8	78	40	330	140	19x4	
400	16"	300	380	55	35	10x8	102	40	386	140	19x4	
450	18"	323	425	55	38	10x8	114	40	433	140	19x4	
500	20"	350	430	90	42	12x8	127	40	487	165	23x4	
550	22"	395	460	90	50	12x8	154	40	536	165	23x4	
600	24"	407	500	90	50	12x8	154	40	582	165	23x4	

VALVE SIZE		DIMENSIONS(m/m)						
m/m	inch	A	B	C	E	F	G	
40	1 1/2"	60	150	225	143	137	150	
50	2"	85	165	225	158	137	150	
65	2 1/2"	90	177	225	170	137	150	
80	3"	98	184	225	177	137	150	
100	4"	112	202	225	195	137	150	
125	5"	125	219	225	212	137	150	
150	6"	140	232	225	225	137	150	
200	8"	170	264	345	255	220	200	
250	10"	207	310	345	301	220	200	
300	12"	238	334	345	325	220	200	
350	14"	266			412	270	300	
400	16"	300			437	270	300	
450	18"	323			482	270	300	
500	20"	350			487	290	350	
550	22"	395			517	137	150	
600	24"	407			557	290	350	

FS-051

JIS-10K
鑄鐵閘門閥

CAST IRON GATE VALVE

總號：713 類號：B2107

㊦第7282號

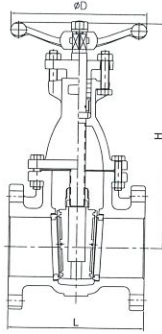

單位/mm

尺寸	2	2 1/2	3	4	5	6	8	10	12
L	180	190	200	230	250	270	290	330	350
H	290	320	350	420	482	545	645	755	850
D	180	180	200	230	250	280	290	330	350

試驗壓力(水壓)

閥體	閥座
20.0kg f/cm ²	15.0kg f/cm ²

零件PART

材質MATERIAL

零件PART	材質MATERIAL	
閥體 BODY	CAST IRON	FC20
閥蓋 BONNET	CAST IRON	FC20
閥桿 STEM	STAINLESS STEEL	SUS410
閥盤 DISC	CAST IRON	FC20
座環 SEAT RING	CAST BRONZE	BC6
壓板 GLAND	DUCTILE IRON	FCD45
迫緊 PACKING	NO ASBESTOS	
手輪 HANDWHEEL	CAST IRON	FC20

FS-052

JIS-10K
鑄鐵昇桿式閘門閥

CAST IRON GATE VALVE Outside screwed & yoke.

總號：715 類號：B2109

㊦第7283號

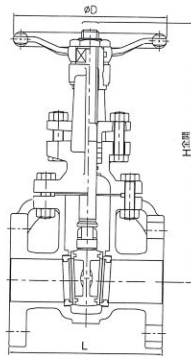

單位/mm

尺寸	2	2 1/2	3	4	5	6	8	10	12
L	180	190	200	230	250	270	290	330	350
H	303	318	368	432	559	622	685	870	1040
D	180	180	200	230	230	270	270	330	350

試驗壓力(水壓)

閥體	閥座
20.0kg f/cm ²	15.0kg f/cm ²

零件PART

材質MATERIAL

零件PART	材質MATERIAL	
閥體 BODY	CAST IRON	FC20
閥蓋 BONNET	CAST IRON	FC20
閥桿 STEM	STAINLESS STEEL	SUS410
閥盤 DISC	CAST IRON	FC20
座環 SEAT RING	CAST BRONZE	BC6
壓板 GLAND	DUCTILE IRON	FCD45
迫緊 PACKING	NO ASBESTOS	
手輪 HANDWHEEL	CAST IRON	FC20

FS-071

JIS-10K
鑄鐵橫式逆止閥

CAST IRON SWING CHECK VALVE

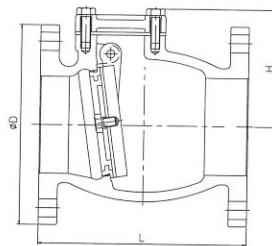

單位/mm

尺寸	2	2 1/2	3	4	5	6	8	10
L	150	165	175	219	242	288	362	410
H	80	88	100	120	135	150	207	245
D	155	175	185	210	250	280	330	400

試驗壓力(水壓)

閥體	閥座
20.0kg f/cm ²	15.0kg f/cm ²

零件PART

材質MATERIAL

零件PART	材質MATERIAL	
閥體 BODY	CAST IRON	FC20
閥蓋 BONNET	CAST IRON	FC20
閥盤 DISC	CAST IRON	FC20
座環 SEAT RING	CAST BRONZE	BC6
閥座迫緊 DISC SEAT	NBR	
銷 HIGH PIN	BRASS	C3604B
塞頭 PLUG	STEEL	SS41

FS-072

JIS-10K 鑄鐵橫式逆止閥

CAST IRON SWING CHECK VALVE

總號：5974 類號：B2513

㊗ 第7284號

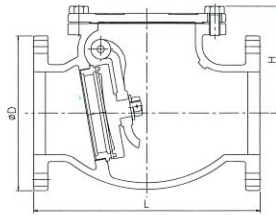
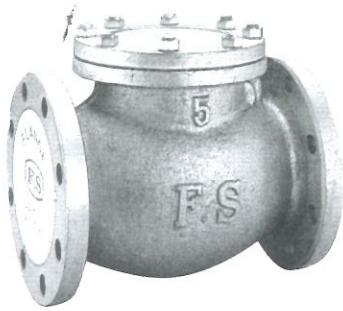

試驗壓力(水壓)

閥體	閥座
20.0kg f/cm ²	15.0kg f/cm ²

零件PART	材質MATERIAL	
閥體 BODY	CAST IRON	FC20
閥蓋 BONNET	CAST IRON	FC20
閥盤 DISC	CAST IRON	FC20
座環 SEAT RING	CAST BRONZE	BC6
塞頭 PLUG	STEEL	SS41
銷 HINGE PIN	BRASS	C3604B

單位/mm

尺寸	2	2 1/2	3	4	5	6	8	10	12
L	200	220	240	290	360	410	500	620	700
H	120	140	150	170	200	230	260	390	440
D	155	175	185	210	250	280	330	400	445

FS-073

JIS-10K 鑄鐵無聲逆止閥

CAST IRON SILENT CHECK VALVE

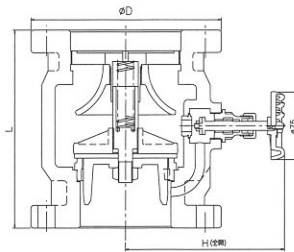

試驗壓力(水壓)

閥體	閥座
20.0kg f/cm ²	15.0kg f/cm ²

零件PART	材質MATERIAL	
閥體 BODY	CAST IRON	FC20
軸心 SPINDLE	BRASS	C3604B
閥盤 DISC	CAST IRON/STAINLESS	FC20/304
閥座橡皮 RUBBER SEAT	NBR / EPDM	
座環 SEAT RING	CAST BRONZE	BC6/304
傘形緩衝器	CAST IRON	FC20
彈簧 SPRING	STAINLESS STEEL	SUS304

註:8及以上為FCD閥體

單位/mm

尺寸	2	2 1/2	3	4	5	6	8	10	12	14	16	18
L	187	200	210	218	255	279	415	555	615	675	830	960
H	163	173	180	190	210	225	245	285	310	340	370	410
D	155	175	185	210	250	280	330	400	445	490	560	620

FS-074

JIS-10K 鑄鐵雙瓣式逆止閥

CAST IRON WAFER TYPE CHECK VALVE

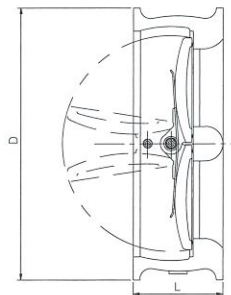

試驗壓力(水壓)

閥體	閥座
20.0kg f/cm ²	15.0kg f/cm ²

零件PART	材質MATERIAL	
閥體 BODY	CAST IRON	FC20
閥盤 DISC	STAINLESS STEEL	SUS304
閥座 SEAT	EPDM	EPDM
彈簧 SPRING	STAINLESS STEEL	SUS304
絞鍊銷 HINGE PIN	STAINLESS STEEL	SUS304
停止銷 STOP PIN	STAINLESS STEEL	SUS304
墊片 WASHER	TEFLON	PTFE

註:最大承製尺寸24"

單位/mm

尺寸	2	2 1/2	3	4	5	6	8	10	12	14	16	18	20	24
L	54	54	57	64	70	76	95	108	143	184	191	203	213	222
D	101	121	131	156	187	217	267	330	375	420	483	538	592	697

FS-075

**JIS-10K
鑄鐵拉柄式底閥**

CAST IRON FULL FLOW FOOT VALVE

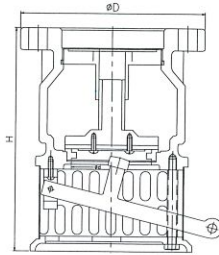

單位/mm

尺寸	2	2 1/2	3	4	5	6	8	10	12
H	179	186	218	224	253	271	395	420	475
D	155	175	185	210	250	280	330	400	445

試驗壓力(水壓)

閥體	閥座
20.0kg f/cm ²	15.0kg f/cm ²

零件PART 材質MATERIAL

閥體 BODY	CAST IRON	FC20
閥盤 DISC	CAST IRON	FC20
座環 SEAT RING	CAST BRONZE	BC6
閥座橡皮 DISC SEAT	NBR	
洗桿 WASHER LEVER	DUCTILE IRON	FCD45
濾網 SCREEN	STAINLESS STEEL	SUS304
底盤 PLATE	CAST IRON	FC20
閥桿 STEM	BRASS	C3604B

FS-081

**JIS-10K
鑄鐵Y型過濾器**

CAST IRON Y-STRAINER

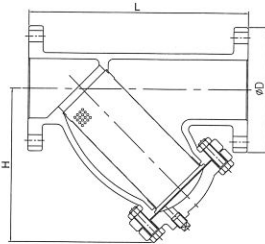

單位/mm

註:8及以上為FCD閥體及閥蓋

尺寸	2	2 1/2	3	4	5	6	8	10	12	14	16	18
L	250	285	315	370	447	508	562	680	800	946	1076	1100
H	175	202	220	272	320	380	410	545	590	661	761	910
D	155	175	185	210	250	280	330	400	445	485	560	620

試驗壓力(水壓)

閥體	閥座
20.0kg f/cm ²	15.0kg f/cm ²

零件PART 材質MATERIAL

閥體 BODY	CAST IRON	FC20
閥蓋 COVER	CAST IRON	FC20
過濾網 SCREEN	STAINLESS STEEL	SUS304
墊片 GASKET	NO ASBESTOS	
塞頭 PLUG	STEEL	SS41

FS-091

**JIS-10K
鑄鐵球型閥**

CAST IRON GLOBE VALVE

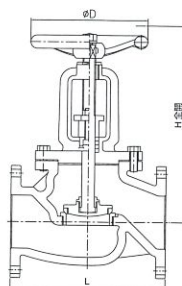

單位/mm

尺寸	2	2 1/2	3	4	5	6	8	10
L	203	216	241	292	356	406	495	622
H	235	265	290	345	375	465	565	570
D	165	185	200	235	270	300	330	360

試驗壓力(水壓)

閥體	閥座
20.0kg f/cm ²	15.0kg f/cm ²

零件PART 材質MATERIAL

閥體 BODY	CAST IRON	FC20
閥蓋 BONNET	CAST IRON	FC20
閥桿 STEM	STAINLESS STEEL	SUS410
閥盤 DISC	CAST IRON	FC20
座環 SEAT RING	CAST BRONZE	BC
壓板 GLAND	DUCTILE IRON	FCD45
迫緊 PACKING	NO ASBESTOS	
手輪 HANDWHEEL	CAST IRON	FC20

鑄鐵系列

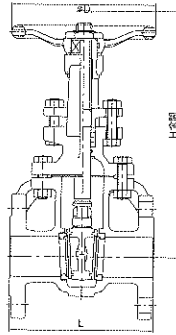
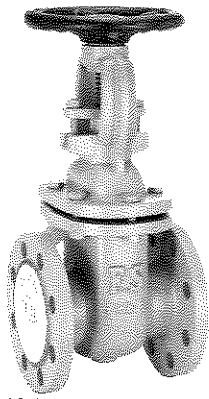
FS-011**JIS-16K**
球墨鑄鐵昇桿式閘門閥**DUCTILE IRON GATE VALVE** Outside screw & yoke

註: JIS-20K產品, 編號 FS-011DK

單位/mm

尺寸	2	2 1/2	3	4	5	6	8	10	12
L	180	190	200	230	250	270	290	330	350
H	303	318	368	432	559	622	685	870	1040
D	180	180	200	230	230	270	270	330	350

註: 閥體採環氧樹脂塗裝, 厚度125±25 Micron

試驗壓力(水壓)	
閥體	閥座
32.0kg f/cm ²	24.0kg f/cm ²

零件PART	材質MATERIAL	
閥體 BODY	DUCTILE IRON	FCD45
閥蓋 BONNET	DUCTILE IRON	FCD45
閥盤 DISC	DUCTILE IRON	FCD45
座環 SEAT RING	CAST BRONZE	BC6/304
閥桿 STEM	STAINLESS STEEL	SUS410
壓板 GLAND	DUCTILE IRON	FCD45
迫緊 PACKING	NO ASBESTOS	
手輪 HANDWHEEL	CAST IRON	FC20

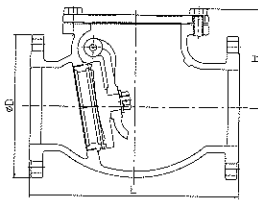
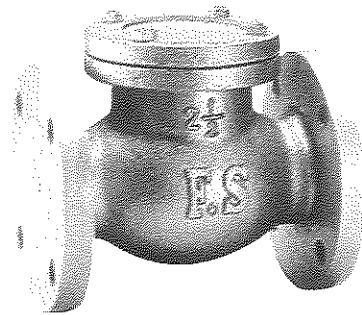
FS-012**JIS-16K**
球墨鑄鐵橫式逆止閥**DUCTILE IRON SWING CHECK VALVE**

註: JIS-20K產品, 編號 FS-012DK

單位/mm

尺寸	2	2 1/2	3	4	5	6	8	10	12
L	203	216	241	292	330	356	495	622	698
H	120	140	150	170	200	230	260	390	440
D	155	175	200	225	270	305	350	430	480

註: 閥體採環氧樹脂塗裝, 厚度125±25 Micron

試驗壓力(水壓)	
閥體	閥座
32.0kg f/cm ²	24.0kg f/cm ²

零件PART	材質MATERIAL	
閥體 BODY	DUCTILE IRON	FCD45
閥蓋 BONNET	DUCTILE IRON	FCD45
閥盤 DISC	DUCTILE IRON	FCD45
座環 SEAT RING	CAST BRONZE	BC6/304
塞頭 PLUG	STEEL	SS41
銷 HINGE PIN	STEEL	SS41
墊片 GASKET	NO ASBESTOS	

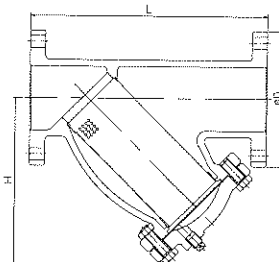
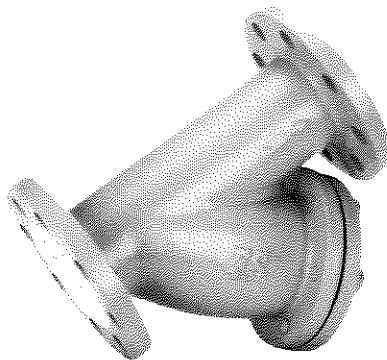
FS-013**JIS-16K**
球墨鑄鐵Y型過濾器**DUCTILE IRON Y-STRAINER** Bolted cover, Y-pattern

註: JIS-20K產品, 編號 FS-013DK

單位/mm

尺寸	2	2 1/2	3	4	5	6	8	10	12	14	16
L	250	285	315	370	447	508	580	680	800	946	1076
H	191	196	210	250	308	370	390	481	566	761	670
D	155	175	200	225	270	305	350	430	480	540	605

註: 閥體採環氧樹脂塗裝, 厚度125±25 Micron

試驗壓力(水壓)	
閥體	閥座
32.0kg f/cm ²	-

零件PART	材質MATERIAL	
閥體 BODY	DUCTILE IRON	FCD45
閥蓋 COVER	DUCTILE IRON	FCD45
過濾網 SCREEN	STAINLESS STEEL	SCS13
墊片 GASKET	NO ASBESTOS	
塞頭 PLUG	STEEL	SS41

FS-014

JIS-16K 球墨鑄鐵球型閥

DUCTILE IRON GLOBE VALVE

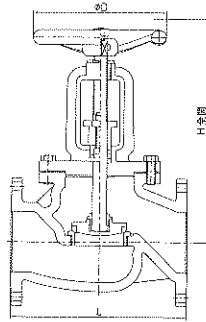
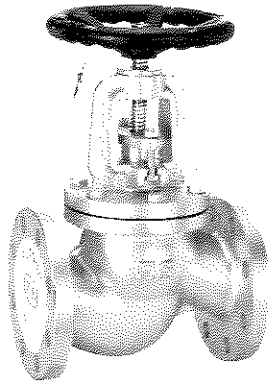

註:JIS-20K產品·編號 FS-014DK

單位/mm

尺寸	2	2 1/2	3	4	5	6	8	10	12	14
L	203	216	241	292	356	406	495	622	698	787
H	235	265	290	345	375	465	565	570	700	780
D	165	185	200	235	270	300	330	360	425	485

註:閥體採環氧樹脂塗裝,厚度125±25 Micron

試驗壓力(水壓)

閥體	閥座
32.0kg f/cm ²	24.0kg f/cm ²

零件PART 材質MATERIAL

零件PART	材質MATERIAL
閥體 BODY	DUCTILE IRON FCD45
閥蓋 BONNET	DUCTILE IRON FCD45
閥桿 STEM	STAINLESS STEEL SUS410
閥盤 DISC	DUCTILE IRON FCD45
座環 SEAT RING	STAINLESS STEEL BC6/SCS13
迫緊 PACKING	NO ASBESTOS
手輪 HANDWHEEL	CAST IRON FC20

FS-015

JIS-16K 球墨鑄鐵把手式蝶型閥

DUCTILE IRON BUTTERFLY VALVE & LEVER

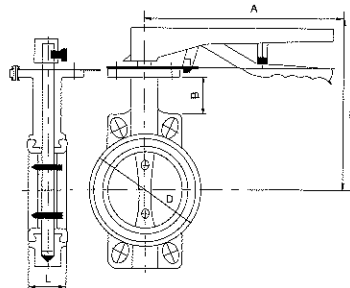
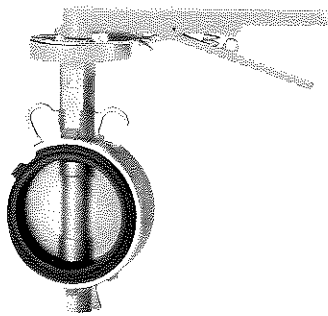

單位/mm

尺寸	2	2 1/2	3	4	5	6	8
L	43	46	46	52	56	56	60
H	174	179	187	202	207	217	259
D	101	120	125	152	187	217	267
A	220	220	220	245	245	245	360
B	83	88	40	45	50	50	45

註:閥體採環氧樹脂塗裝,厚度125±25 Micron

試驗壓力(水壓)

閥體	閥座
24.0kg f/cm ²	17.6kg f/cm ²

零件PART 材質MATERIAL

零件PART	材質MATERIAL
閥體 BODY	DUCTILE IRON FCD45
閥座 SEAT	NBR(80°C) / EPDM(120°C)
檔流盤 DISC	STAINLESS STEEL SCS13
閥桿 STEM	STAINLESS STEEL SUS304
O型環 O-RING	NBR
彈簧 SPRING	STAINLESS STEEL SUS304
固定片 PLATE	CARBON STEEL SS41
把手 HANDLE	DUCTILE IRON FCD45

FS-016

JIS-16K 球墨鑄鐵齒輪式蝶型閥

DUCTILE IRON BUTTERFLY VALVE & GEAR

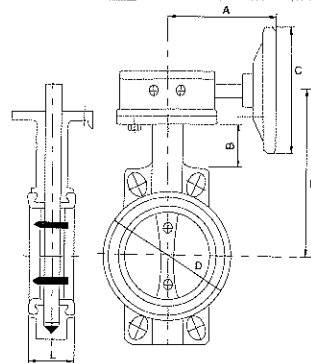
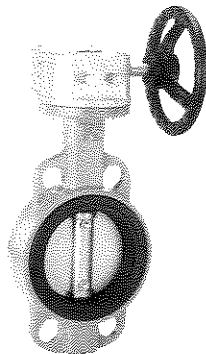

單位/mm

尺寸	2	2 1/2	3	4	5	6	8	10	12	14	16	18	20	24
L	43	46	46	52	56	56	60	68	78	78	102	114	127	164
H	158	170	177	195	212	225	255	301	325	412	437	482	487	557
D	101	120	125	152	187	217	267	327	375	415	480	530	580	720
A	185	185	185	185	185	185	280	280	280	375	375	375	290	290
B	83	88	40	45	50	50	45	40	45	70	75	75	77	80
C	150	150	150	150	150	150	250	250	250	350	350	350	410	410

註:閥體採環氧樹脂塗裝,厚度125±25 Micron

試驗壓力(水壓)

閥體	閥座
24.0kg f/cm ²	17.6kg f/cm ²

零件PART 材質MATERIAL

零件PART	材質MATERIAL
閥體 BODY	DUCTILE IRON FCD45
閥座 SEAT	NBR(80°C) / EPDM(120°C)
檔流盤 DISC	STAINLESS STEEL BC/SCS13
閥桿 STEM	STAINLESS STEEL SUS304
O型環 O-RING	NBR
彈簧 SPRING	STAINLESS STEEL SUS304
齒輪操作器 GEAR BOX	CAST IRON FC20

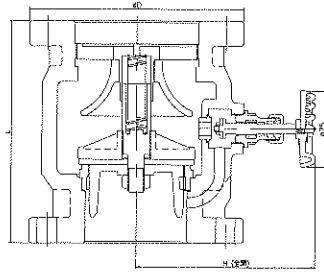
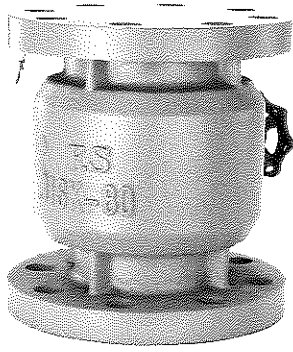
FS-017**JIS-16K
球墨鑄鐵無聲逆止閥****DUCTILE IRON SILENT CHECK VALVE**

註:可承製JIS-20K產品, 編號為FS-017DK

單位/mm

尺寸	2	2 1/2	3	4	5	6	8	10	12
L	187	200	210	218	255	279	415	555	615
H	163	173	180	190	210	225	245	285	310
D	155	175	200	225	270	305	350	430	480

註:閥體採環氧樹脂塗裝, 厚度125±25 Micron

試驗壓力(水壓)	
閥體	閥座
32.0kg f/cm ²	24.0kg f/cm ²

零件PART	材質MATERIAL	
閥體 BODY	DUCTILE IRON	FCD45
閥盤 DISC	CAST IRON/STAINLESS	FC20/304
軸心 SPINDLE	BRASS	C3604B
傘形緩衝器	CAST IRON	FC20
座環 SEAT RING	CAST BRONZE	BC6/304
閥座橡皮 RUBBER SEAT	NBR	

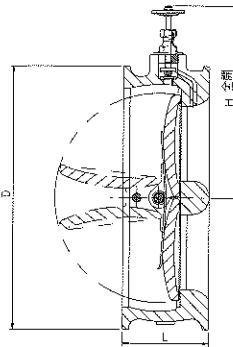
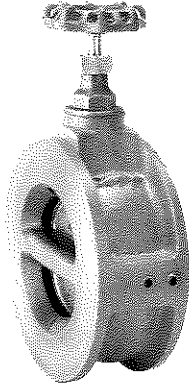
FS-018**JIS-16K
球墨鑄鐵雙瓣式逆止閥****DUCTILE IRON WAFER TYPE CHECK VALVE**

註:可承製JIS-20K產品, 編號為FS-018K

單位/mm

尺寸	2	2 1/2	3	4	5	6	8	10	12	14	16	18	20	24
L	54	54	57	64	70	76	95	108	143	184	191	203	213	222
H	138	148	156	168	181	201	227	256	283	311	337	373	393	445
D	101	121	137	162	197	235	279	353	403	447	507	572	627	731

註:閥體採環氧樹脂塗裝, 厚度125±25 Micron

試驗壓力(水壓)	
閥體	閥座
24.0kg f/cm ²	17.6kg f/cm ²

零件PART	材質MATERIAL	
閥體 BODY	DUCTILE IRON	FCD45
閥盤 DISC	STAINLESS STEEL	SCS13
閥座 SEAT	NBR / EPDM / VITON	
彈簧 SPRING	STAINLESS STEEL	SUS316
鉸鏈銷 HINGE PIN	STAINLESS STEEL	SUS304
停止銷 STOP PIN	STAINLESS STEEL	SUS304
墊片 WASHER	TEFLON	PTFE
BY-PASS	BRONZE VALVE	BC

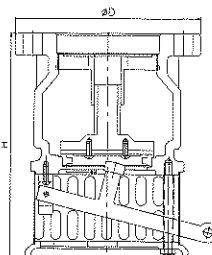
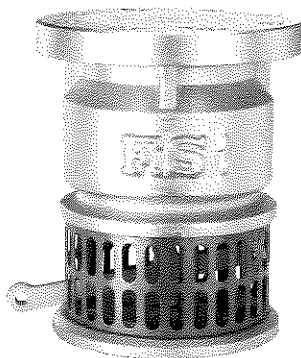
FS-019**JIS-16K
球墨鑄鐵拉柄式底閥****DUCTILE IRON FULL FLOW FOOT VALVE**

單位/mm

尺寸	2	2 1/2	3	4	5	6	8	10	12
H	179	186	218	224	253	271	395	420	475
D	155	175	200	225	270	305	350	430	480

註:閥體採環氧樹脂塗裝, 厚度125±25 Micron

試驗壓力(水壓)	
閥體	閥座
32.0kg f/cm ²	24.0kg f/cm ²

零件PART	材質MATERIAL	
閥體 BODY	DUCTILE IRON	FCD45
閥盤 DISC	CAST IRON	FC20
座環 SEAT RING	CAST BRONZE	BC6/304
閥座橡皮 DISC SEAT	NBR	
洗桿 WASHER LEVER	DUCTILE IRON	FCD45
濾網 SCREEN	STAINLESS STEEL	SUS304
底盤 PLATE	CAST IRON	FC20
閥桿 STEM	BRASS	C3604B

FS-021D 把手式偏心蝶閥

DUCTILE IRON ECCENTRIC BUTTERFLY VALVE & LEVER

FS-022D 齒輪式偏心蝶閥

DUCTILE IRON ECCENTRIC BUTTERFLY VALVE & GEAR

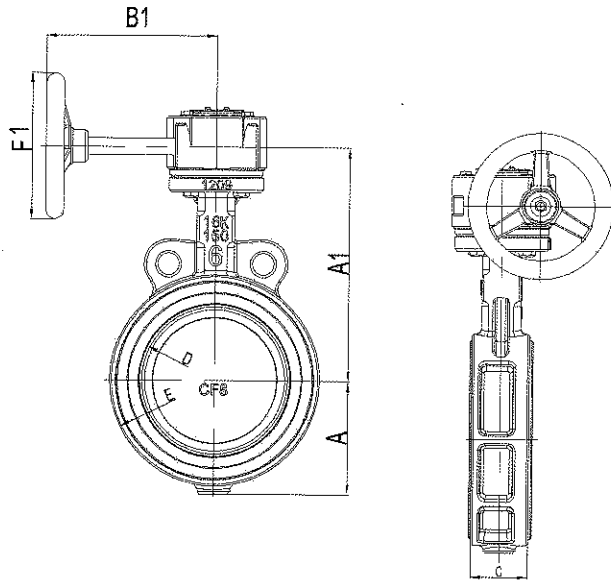
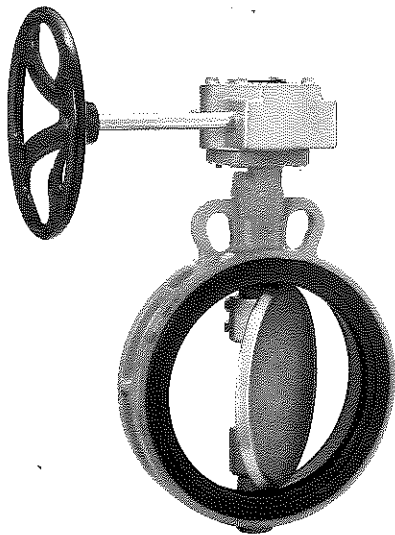
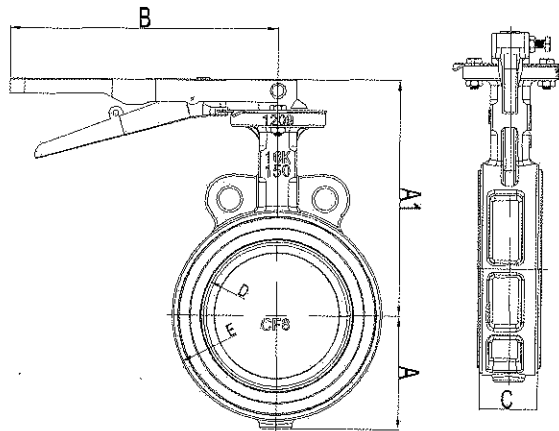

球墨鐵系列

Flanges: JIS 10K 16K 共用

FACE TO FACE: ISO 5752

MOUNTING PAD: ISO 5211 TABLE 5.

TEST INSPECTION: ISO 5208 API-598

TEST PRESSURE: Body 24kg/cm²
: Seat 17.6kg/cm²

單位/mm

VALVE SIZE	A	A1	B	B1	C	D	E	F
2.5"	65	62	160	220	165	46	63	113
3"	80	70	171	220	165	46	79	128
4"	100	83	193	220	165	52	100	151
5"	125	98	215	260	165	56	123	182
6"	150	110	230	260	165	56	148	206
8"	200	139	266	360	280	60	197	258
10"	250	170	305	360	280	68	243	320
12"	300	200	342	360	280	78	290	374

序號	名稱	數量	材質	序號	名稱	數量	材質	序號	名稱	數量	材質
1	密封圈墊片	1	EPDM	8	密封圈墊片	1	EPDM	15	齒盤	1	SS41
2	內六角螺絲M6x12	2	SS41	9	閘桿	1	A182F 304	15-1	齒輪箱	1	CAST IRON
3	壓版	1	SS41	10	插銷	1	A182F 304	16	外六角螺絲 M8x25	3	SS41
4	密封墊圈	1	EPDM	11	O型密封圈	2	EPDM	16-1	手輪	1	CAST IRON
5	閘版	1	A351 CF8	12	襯套	1	PTFE	17	手把	1	DUCTILE IRON
6	閘體	1	FCD45	13	E型扣環	1	SS41	17-1	螺絲及墊片 M6x12	1	SS41
7	外六角螺絲M8x25	4	SS41	14	螺母	2	SS41	18-1	螺絲及墊片 M8x45	2	SS41

FS-021
FS-022

把手式
齒輪式

偏心夾式
全法蘭型蝶閥

STAINLESS STEEL DOUBLE ECCENTRIC BUTTERFLY VALVE

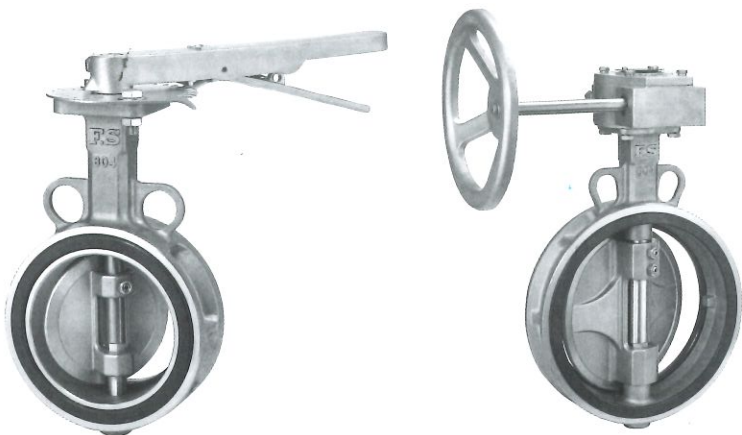

Flanges: JIS 10K.16K
ANSI B16.1 class 125
ANSI B16.5 class 150

FACE TO FACE: ISO 5752
MOUNTING PAD: ISO 5211 TABLE 5.
TEST INSPECTION: ISO 5208 API-598

TEST PRESSURE: Body 20kg/cm²
: Seat 12kg/cm²

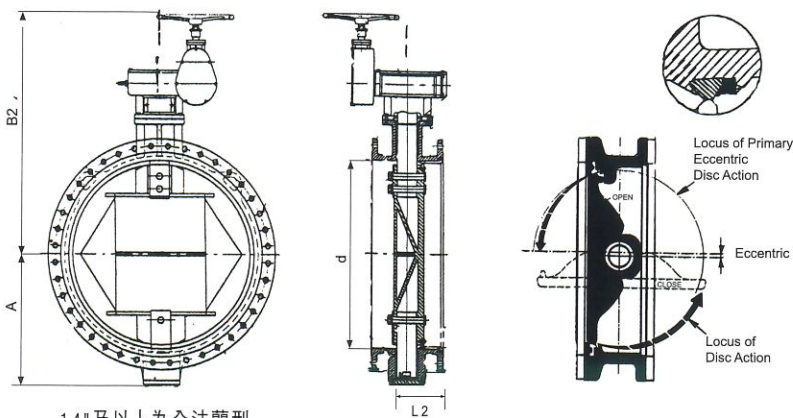
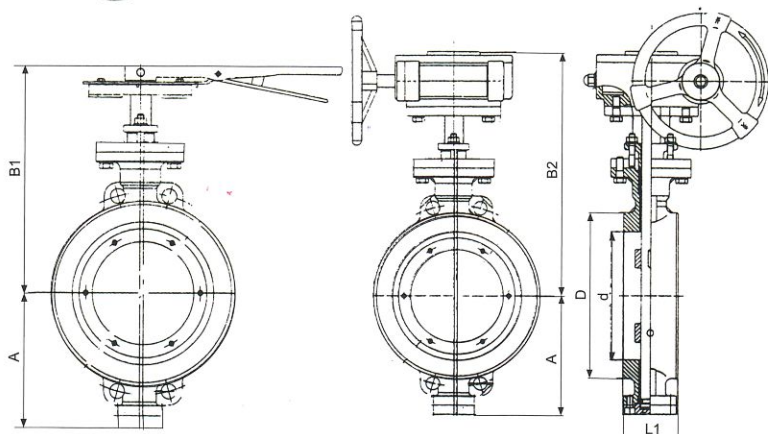

14"及以上為全法蘭型

零件PART	材質MATERIAL		可變更材質
閥體 BODY	SCS13	A351CF8	CF8M
閥座 SEAT	EPDM		
閥座 SEAT	SCS13	A351 CF8	CF8M
閥桿 STEM	SUS304	A182F304	SUS316
葉片 DISC	SCS13	A351CF8	CF8M
固定片 BUSHING	304		316
彈簧 O-RING	304		316
把手 LEVER	SCS13	A351CF8	
齒輪操作器 GEAR BOX	FC20	A126	SCS13

KV VALUE	OPENING POSITION			TORQUE (Nm)
	30°	60°	90°	
21/2	20	70	150	50
3"	22	78	168	60
4"	38	168	365	80
5"	74	312	654	150
6"	115	480	995	220
8"	218	919	1920	400
10"	339	1298	3286	600
12"	458	1946	4598	900
14"	596	2397	6078	1300
16"	688	2769	7285	1500
18"	876	3674	9144	2400
20"	1087	4887	11698	3500
24"	1748	7696	17355	4250

SIZE	A	B1/B2	d	D	L1	L2
80	70	171/241	76	128	46	-
100	83	193/263	100	151	52	-
125	98	215/285	125	182	56	-
150	110	230/300	150	206	56	-
200	139	266/389	200	258	60	-
250	250	428	250	320	68	-
300	300	465	300	374	78	-
350	505	520	350	429	-	190
400	540	560	400	480	-	216
450	580	600	450	548	-	222
500	625	650	500	609	-	229
600	700	720	600	720	-	267
700	765	790	700	794	-	292
800	840	870	800	901	-	318

* 14"(含)以上為全法蘭型

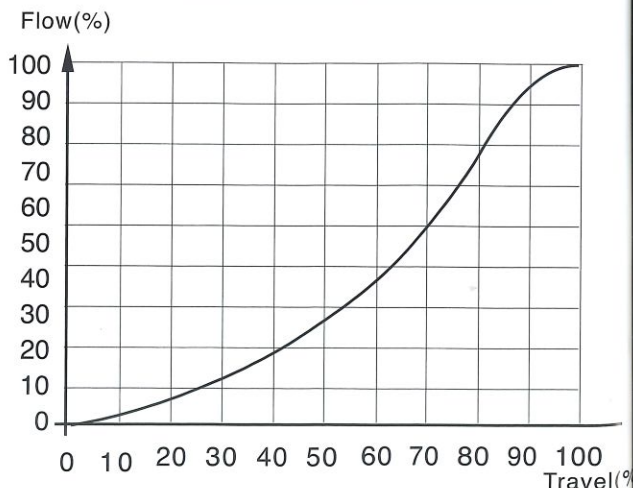

不銹鋼系列

FS-065S**10K
304****減壓閥****STAINLESS STEEL
PRESSURE REDUCING VALVE****產品試壓**

標稱壓力	10K
閥體試壓	20 kg/m ² 水壓 5分鐘零洩漏
閥座試壓	15 kg/m ² 水壓 3分鐘零洩漏
出口側調壓範圍	1~12 kg/m ²
最高工作溫度 適用流體	80°C 水、自來水

設計標準 EN1074

結構長度標準：T219

法蘭標準：JIS B2212 10K

測試標準：EN12266

閥前安裝過濾器防止雜物進入閥腔。

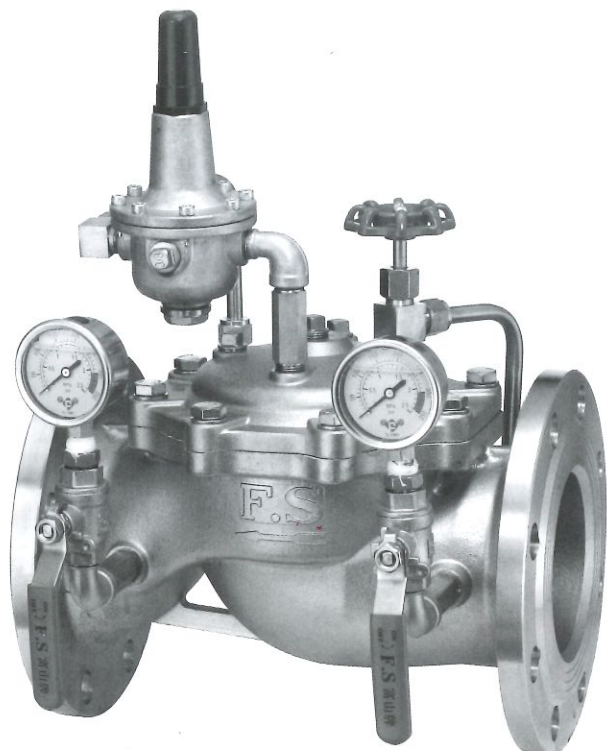

固溶化熱處理 CNS4000 G3092

註1：JIS-16K產品，編號FS-065SK

註2：可訂製禁油品

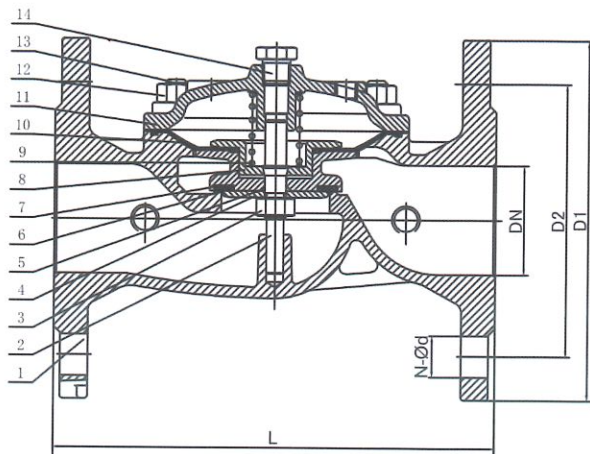
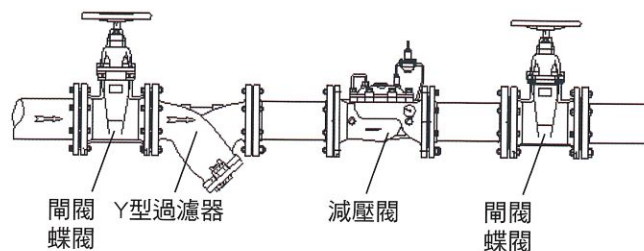
**主要名稱及材質**

序號	主要零件名稱	材質
1	閥體	304
2	閥桿	304
3	閥桿六角螺母	304
4	密封圈壓板	304
5	O型圈	NBR
6	密封圈	NBR
7	閥盤	304
8	膜片壓套	304
9	彈簧	不鏽鋼
10	膜片	EPDM
11	閥蓋	304
12	六角螺母	304
13	六角螺栓	304
14	螺塞	304
15	減壓子閥及配件	304

size	D1	D2	N-Ød	L
2"	155	120	4-19	203
2½"	175	140	4-19	216
3"	185	150	8-19	241
4"	210	175	8-19	292
5"	250	210	8-23	330
6"	280	240	8-23	356
8"	330	290	12-23	495

特殊閥系列

FS-066S

10K
304

持壓閥

洩壓閥

STAINLESS STEEL PRESSURE SUSTAINING VALVE

STAINLESS STEEL PRESSURE RELIEF VALVE

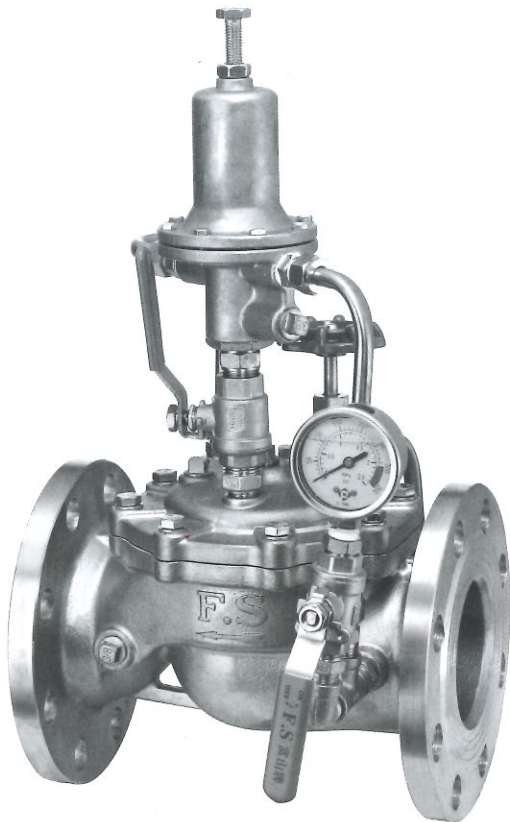

固溶化熱處理 CNS4000 G3092
 註1：JIS-16K產品，編號FS-066SK
 註2：可訂製禁油品

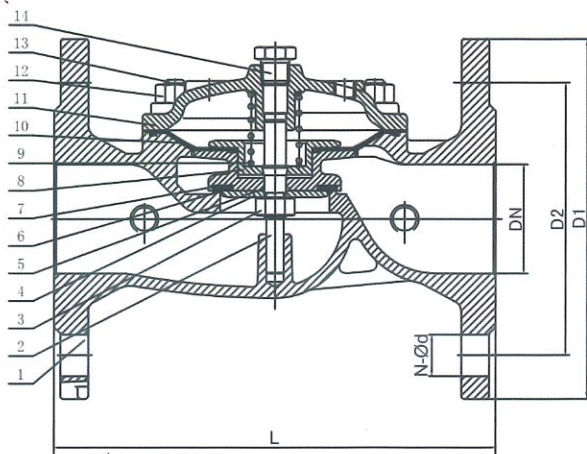

產品試壓

標稱壓力	10K
閥體試壓	20 kg/m ² 水壓 5分鐘零洩漏
閥座試壓	15 kg/m ² 水壓 3分鐘零洩漏
入口側調壓範圍	持壓閥/洩壓閥 2-13 kg/m ²
最高工作溫度 適用流體	80°C 水、自來水

設計標準 EN1074
 結構長度標準：T219
 法蘭標準：JIS B2212 10K
 測試標準：EN12266
 閥前安裝過濾器防止雜物進入閥腔。

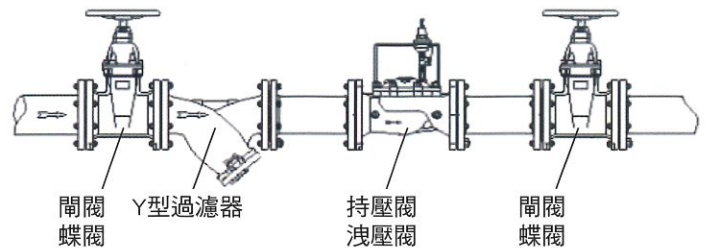

主要名稱及材質

序號	主要零件名稱	材質
1	閥體	304
2	閥桿	304
3	閥桿六角螺母	304
4	密封圈壓板	304
5	O型圈	NBR
6	密封圈	NBR
7	閥盤	304
8	膜片壓套	304
9	彈簧	不鏽鋼
10	膜片	EPDM
11	閥蓋	304
12	六角螺母	304
13	六角螺栓	304
14	螺塞	304
15	持壓/洩壓子閥及配件	304

size	D1	D2	N-Ød	L
2"	155	120	4-19	203
2½"	175	140	4-19	216
3"	185	150	8-19	241
4"	210	175	8-19	292
5"	250	210	8-23	330
6"	280	240	8-23	356
8"	330	290	12-23	495

FS-067S

10K
304

定水位閥
遙控浮球閥

STAINLESS STEEL FLOAT CONTROL VALVE

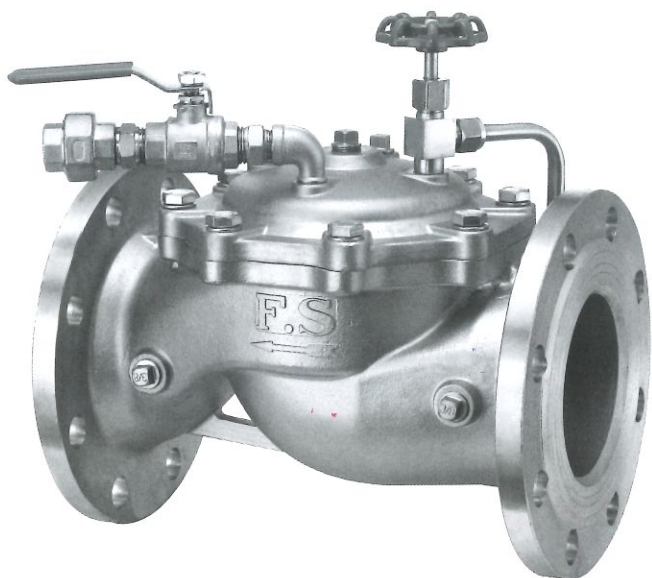

固溶化熱處理 CNS4000 G3092
註1：JIS-16K產品，編號FS-067SK

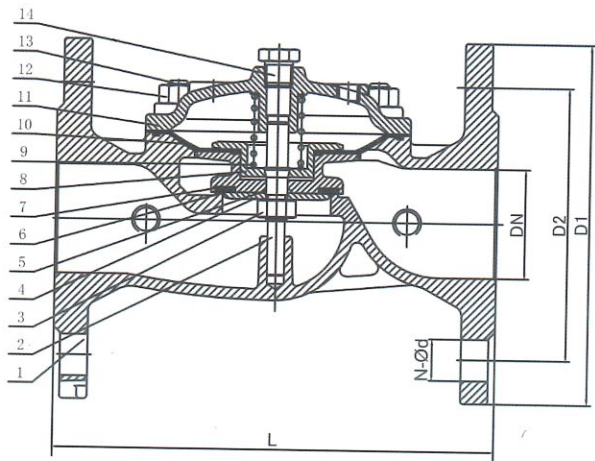

產品試壓

標稱壓力	10K
閥體試壓	20 kg/m ² 水壓 5分鐘零洩漏
閥座試壓	15 kg/m ² 水壓 3分鐘零洩漏
最小工作壓力	0.7 kg/m ² 以上
最高工作溫度 適用流體	80°C 水、自來水

設計標準 EN1074
結構長度標準：T219
法蘭標準：JIS B2212 10K
測試標準：EN12266
閥前安裝過濾器防止雜物進入閥腔。

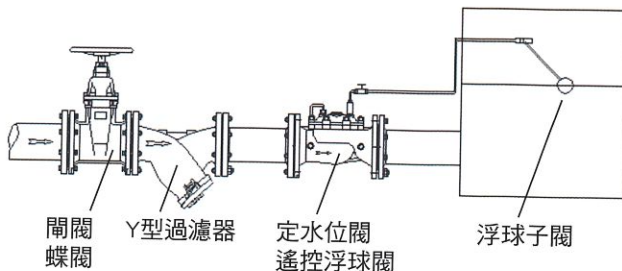

主要名稱及材質

序號	主要零件名稱	材質
1	閥體	304
2	閥桿	304
3	閥桿六角螺母	304
4	密封圈壓板	304
5	O型圈	NBR
6	密封圈	NBR
7	閥盤	304
8	膜片壓套	304
9	彈簧	不鏽鋼
10	膜片	EPDM
11	閥蓋	304
12	六角螺母	304
13	六角螺絲	304
14	螺塞	304
15	浮球子閥及配件	304

size	D1	D2	N-Ød	L
2"	155	120	4-19	203
2½"	175	140	4-19	216
3"	185	150	8-19	241
4"	210	175	8-19	292
5"	250	210	8-23	330
6"	280	240	8-23	356
8"	330	290	12-23	495

特殊閥系列

FS-065F
FS-065FK

10K

16K

球墨鑄鐵

減壓閥

DUCTILE IRON
PRESSURE REDUCING VALVE

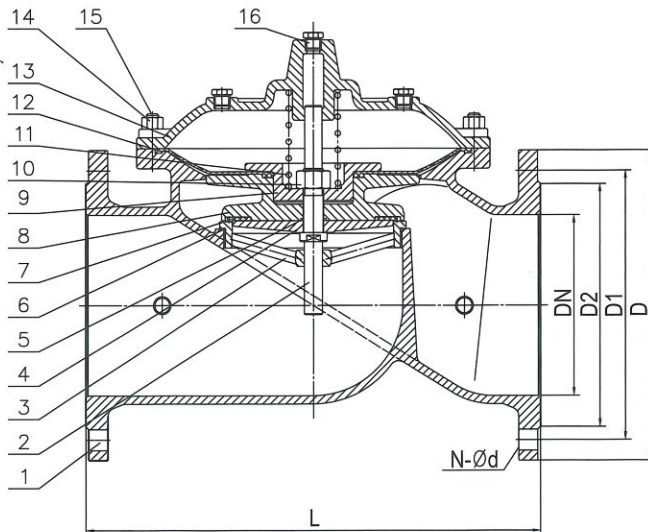
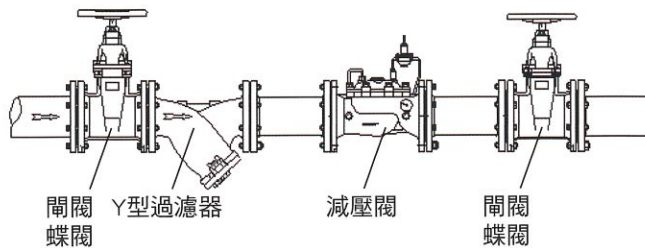
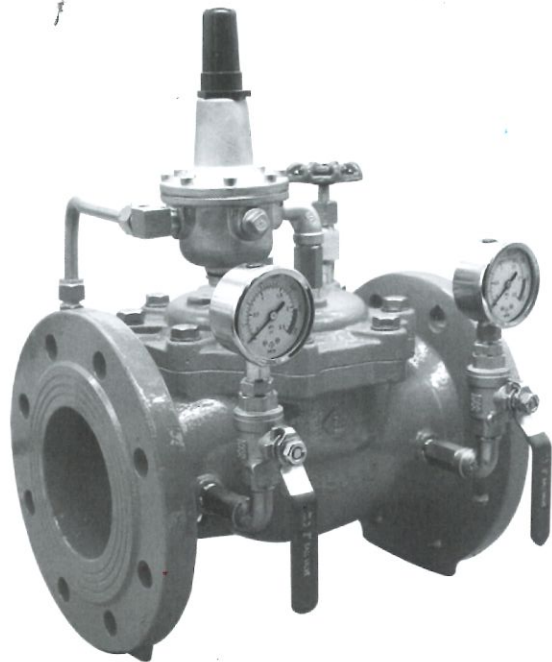

產品試壓

	JIS 10K	JIS 16K
標稱壓力	10K	16K
閥體試壓	20 kg/m ² 水壓 5分鐘零洩漏	32 kg/m ² 水壓 5分鐘零洩漏
閥座試壓	15 kg/m ² 水壓 3分鐘零洩漏	24 kg/m ² 水壓 3分鐘零洩漏
出口測調壓範圍	1~12 kg/m ²	1~12 kg/m ²
最高工作溫度	80°C	80°C
適用流體	水、自來水	水、自來水

設計標準：EN1074

結構長度標準：T219

法蘭標準：JIS B2212 10K / JIS B2213 16K

測試標準：EN12266

閥前安裝過濾器防止雜物進入閥腔。

閥門表面用環氧樹脂粉末塗裝，符合T17219 規定。

主要名稱及材質

序號	主要零件名稱	材質
1	閥體	FCD45
2	閥桿	不鏽鋼
3	閥座	304
4	密封圈壓板	不鏽鋼
5	O型圈	NBR
6	O型圈	NBR
7	密封圈	EPDM
8	閥盤	304
9	膜片壓套	304
10	閥桿六角螺母	304
11	彈簧	不鏽鋼
12	膜片	EPDM
13	閥蓋	FCD45
14	六角螺母	304
15	雙頭螺栓	304
16	塞頭	304
17	減壓子閥及配件	304

size	DN	L	10K			16K		
			D1	D2	N-Ød	D1	D2	N-Ød
2	50	203	155	120	4-19	155	120	8-19
2½"	65	216	175	140	4-19	175	140	8-19
3	80	241	185	150	8-19	200	160	8-22
4	100	292	210	175	8-19	225	185	8-22
5	125	330	250	210	8-23	270	225	8-25
6	150	356	280	240	8-23	305	260	12-25
8	200	495	330	290	12-23	350	305	12-25

FS-066F
FS-066FK

10K

16K

球墨鑄鐵

持壓閥

洩壓閥

DUCTILE IRON PRESSURE SUSTAINING VALVE

DUCTILE IRON PRESSURE RELIEF VALVE

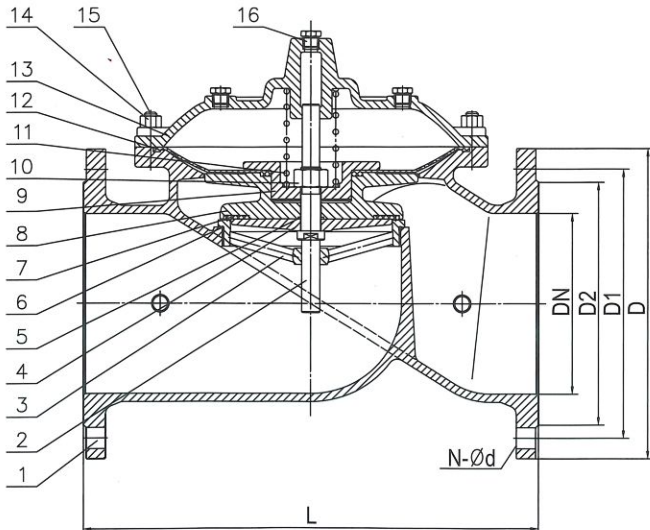
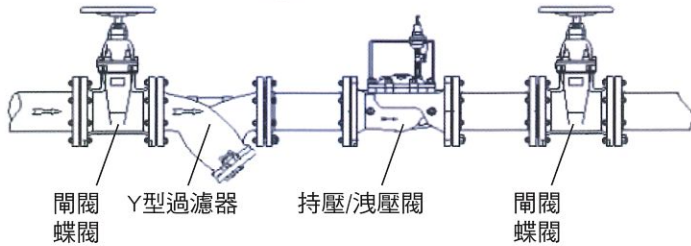
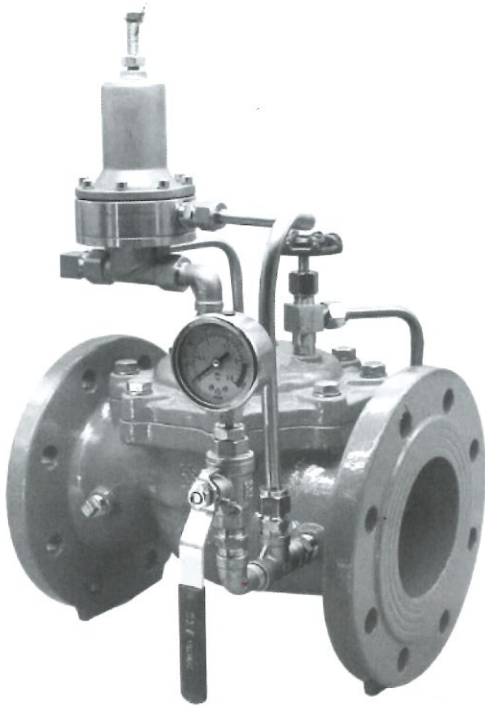

產品試壓

	JIS 10K	JIS 16K
標稱壓力	10K	16K
閥體試壓	20 kg/m ² 水壓 5分鐘零洩漏	32 kg/m ² 水壓 5分鐘零洩漏
閥座試壓	15 kg/m ² 水壓 3分鐘零洩漏	24 kg/m ² 水壓 3分鐘零洩漏
入口測調壓範圍	持壓閥/洩壓閥 2~13 kg/m ²	持壓閥/洩壓閥 2~13 kg/m ²
最高工作溫度 適用流體	80°C 水、自來水	80°C 水、自來水

設計標準：EN1074

結構長度標準：T219

法蘭標準：JIS B2212 10K / JIS B2213 16K

測試標準：EN12266

閥前安裝過濾器防止雜物進入閥腔。

閥門表面用環氧樹脂粉末塗裝，符合T17219 規定。

主要名稱及材質

序號	主要零件名稱	材質
1	閥體	FCD45
2	閥桿	不鏽鋼
3	閥座	304
4	密封圈壓板	不鏽鋼
5	O型圈	NBR
6	O型圈	NBR
7	密封圈	EPDM
8	閥盤	304
9	膜片壓套	304
10	閥桿六角螺母	304
11	彈簧	不鏽鋼
12	膜片	EPDM
13	閥蓋	FCD45
14	六角螺母	304
15	雙頭螺栓	304
16	塞頭	304
17	減壓/洩壓子閥及配件	304

size	DN	L	10K			16K		
			D1	D2	N-Ød	D1	D2	N-Ød
2	50	203	155	120	4-19	155	120	8-19
2½"	65	216	175	140	4-19	175	140	8-19
3	80	241	185	150	8-19	200	160	8-22
4	100	292	210	175	8-19	225	185	8-22
5	125	330	250	210	8-23	270	225	8-25
6	150	356	280	240	8-23	305	260	12-25
8	200	495	330	290	12-23	350	305	12-25

特殊閥系列

FS-067F
FS-067FK

10K
16K

球墨鑄鐵

定水位閥
遙控浮球閥

DUCTILE IRON
FLOAT CONTROL VALVE

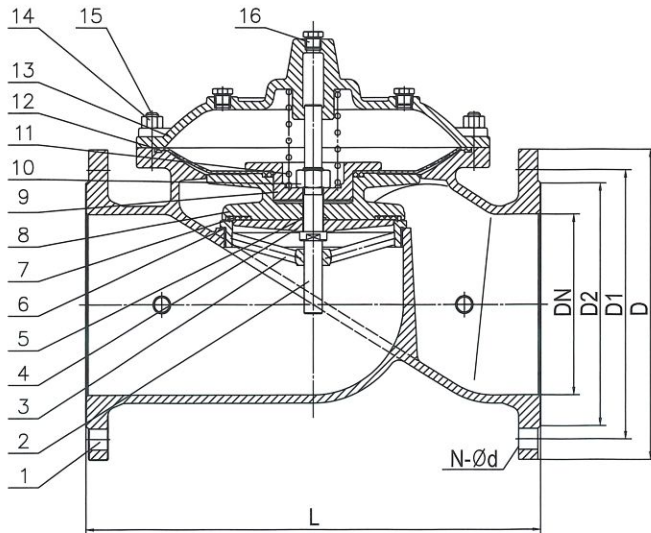
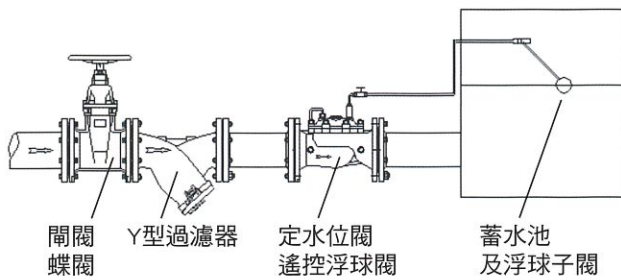
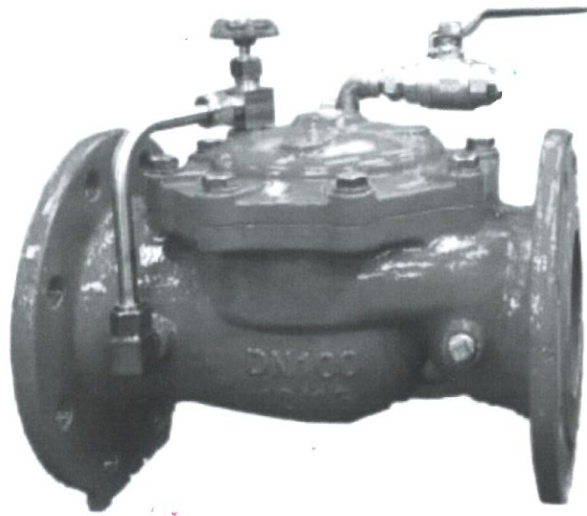

產品試壓		
	JIS 10K	JIS 16K
標稱壓力	10K	16K
閥體試壓	20 kg/m ² 水壓 5分鐘零洩漏	32 kg/m ² 水壓 5分鐘零洩漏
閥座試壓	15 kg/m ² 水壓 3分鐘零洩漏	24 kg/m ² 水壓 3分鐘零洩漏
最小工作壓力	0.7 kg/m ² 以上	0.7 kg/m ² 以上
最高工作溫度	80°C	80°C
適用流體	水、自來水	水、自來水

設計標準：EN1074

結構長度標準：T219

法蘭標準：JIS B2212 10K / JIS B2213 16K

測試標準：EN12266

閥前安裝過濾器防止雜物進入閥腔。

閥門表面用環氧樹脂粉末塗裝，符合T17219 規定。

主要名稱及材質		
序號	主要零件名稱	材質
1	閥體	FCD45
2	閥桿	不鏽鋼
3	閥座	304
4	密封圈壓板	不鏽鋼
5	O型圈	NBR
6	O型圈	NBR
7	密封圈	EPDM
8	閥盤	304
9	膜片壓套	304
10	閥桿六角螺母	304
11	彈簧	不鏽鋼
12	膜片	EPDM
13	閥蓋	FCD45
14	六角螺母	304
15	雙頭螺栓	304
16	塞頭	304
17	浮球子閥及配件	304

size	DN	L	10K			16K		
			D1	D2	N-Ød	D1	D2	N-Ød
2	50	203	155	120	4-19	155	120	8-19
2½"	65	216	175	140	4-19	175	140	8-19
3	80	241	185	150	8-19	200	160	8-22
4	100	292	210	175	8-19	225	185	8-22
5	125	330	250	210	8-23	270	225	8-25
6	150	356	280	240	8-23	305	260	12-25
8	200	495	330	290	12-23	350	305	12-25

FS-068K

16K

**球墨鑄鐵
壓力調整閥**

**DUCTILE IRON
PRESSURE REDUCING VALVE FOR FIRE FIGHTING**

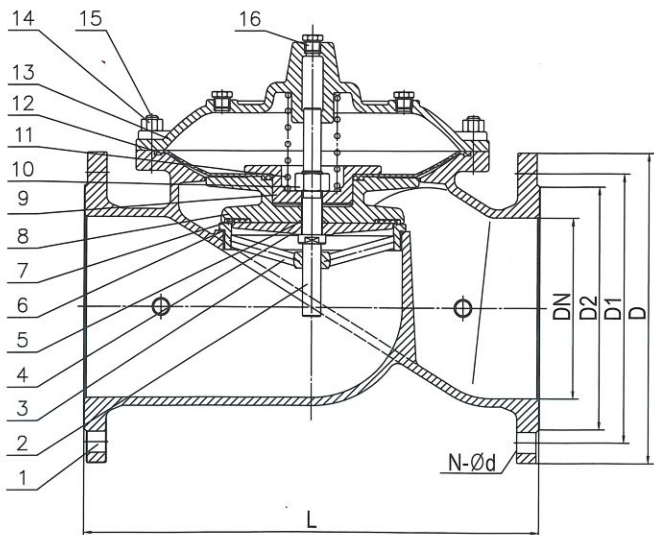
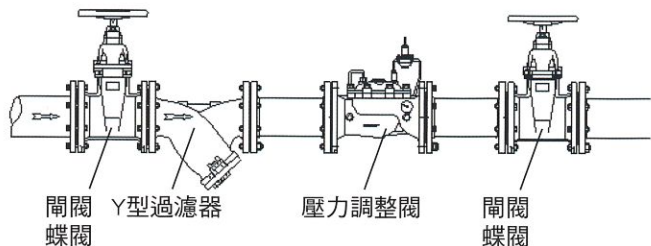
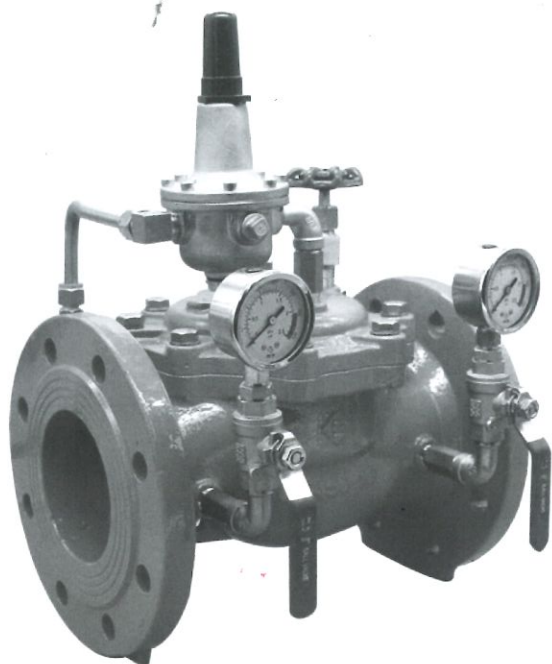

產品試壓	
標稱壓力	16K
閘體試壓	32 kg/m ² 水壓 5分鐘零洩漏
閘座試壓	24 kg/m ² 水壓 5分鐘零洩漏
出口測調壓範圍	0.5~4 kg/m ² 需0.7 kg/m ² 以上
最高工作溫度 適用流體	80°C 水、自來水

設計標準：EN1074
 結構長度標準：T10674
 法蘭標準：JIS B2213 16K
 測試標準：EN12266
 閘前安裝過濾器防止雜物進入閘腔。
 閘門表面用環氧樹脂粉末塗裝，符合T17219 規定。

主要名稱及材質		
序號	主要零件名稱	材質
1	閘體	FCD45
2	閘桿	不鏽鋼
3	閘座	304
4	密封圈壓板	不鏽鋼
5	O型圈	NBR
6	O型圈	NBR
7	密封圈	EPDM
8	閘盤	304
9	膜片壓套	304
10	閘桿六角螺母	304
11	彈簧	不鏽鋼
12	膜片	EPDM
13	閘蓋	FCD45
14	六角螺母	304
15	雙頭螺栓	304
16	塞頭	304
17	減壓子閘及配件	304

size	DN	L	10K			16K		
			D1	D2	N-Ød	D1	D2	N-Ød
2	50	205	155	120	4-19	155	120	8-19
2 ¹ / ₂ "	65	250	175	140	4-19	175	140	8-19
3	80	250	185	150	8-19	200	160	8-22
4	100	320	210	175	8-19	225	185	8-22
5	125	415	250	210	8-23	270	225	8-25
6	150	415	280	240	8-23	305	260	12-25
8	200	500	330	290	12-23	350	305	12-25

特殊閘系列

銅/不銹鋼材料成分標準

原料	代號	Cu% 銅	Sn% 錫	Pb% 鉛	Zn% 鋅	P% 磷	Fe% 鐵	Si% 矽	Al% 鋁	Ni% 鎳	Bi% 鉍	Mn% 錳
黃銅	YBSC3, CAC203	58.0~64.0	1.0↓	0.5~3.0	30.0~41.0	-	0.8↓	-	0.50↓	-	-	-
	ASTM C85700	58.0~64.0	0.5~1.5	0.8~1.5	32.0~40.0	-	0.7↓	-	0.80↓	1.0↓	-	-
	BC1 CAC401	79.0~83.0	2.0~4.0	3.0~7.0	8.0~12.0	-	-	-	-	-	-	-
	ASTM 84400	78.0~82.0	2.3~3.5	6.0~8.0	7.0~10.0	-	0.4↓	-	0.005↓	1.0↓	-	-
青銅	BC6, CAC406	83.0~87.0	4.0~6.0	4.0~6.0	4.0~6.0	-	-	-	-	-	-	-
	ASTM 83600	84.0~86.0	4.0~6.0	4.0~6.0	4.0~6.0	-	0.3↓	-	0.005↓	1.0↓	-	-
	ASTM C37700	58.0~61.0	-	1.5~2.5	餘量	-	0.3↓	-	-	-	-	-
	JIS C3771B	57.0~61.0	-	1.0~2.5	餘量	-	Fe+Sn1.0以下	-	-	-	-	-
鍛造黃銅	ASTM C89844	83.0~86.0	3.0~5.0	0.2↓	7.0~10.0	0.05↓	0.3↓	0.005↓	0.005↓	1.0↓	2.0~4.0	-
	ASTM C87500	79.0↑	-	0.09↓	12.0~16.0	-	-	3.0~5.0	0.5↓	-	-	-
	ASTM C46400	59.0~62.0	0.5~1.0	0.2↓	餘量	-	0.1↓	-	-	-	-	-
	無鉛 無鉛鈹銅 (鉛0.25%以下)	無鉛鈹銅 ASTM C87500	無鉛鈹銅 ASTM C87500	無鉛鈹銅 ASTM C87500	無鉛鈹銅 ASTM C87500	無鉛鈹銅 ASTM C87500	無鉛鈹銅 ASTM C87500	無鉛鈹銅 ASTM C87500	無鉛鈹銅 ASTM C87500	無鉛鈹銅 ASTM C87500	無鉛鈹銅 ASTM C87500	無鉛鈹銅 ASTM C87500

不銹鋼 304	標準	總號	代號	C% 碳	Si% 矽	Mn% 錳	P% 磷	S% 硫	Ni% 鎳	Cr% 鉻	Mo% 鉬	N% 氮	Cu% 銅	降伏強度 (MPa)	抗拉強度 (MPa)	伸長率 (%)	硬度 (HB)
	CNS	4000	SCS13A	≤0.08	≤2.0	≤1.5	≤0.04	≤0.04	8.0~11.0	18.0~21.0	-	-	-	-	≥205	≥480	≥33
JIS	G5121	SCS13A	≤0.08	≤2.0	≤1.5	≤0.04	≤0.04	8.0~11.0	18.0~21.0	-	-	-	-	≥205	≥480	≥33	≤183
	A351 A743 A744	CF-8	≤0.08	≤2.0	≤1.5	≤0.04	≤0.04	8.0~11.0	18.0~21.0	-	-	-	-	≥205	≥485	≥30	-
CNS	4000	SCS14A	≤0.08	≤1.5	≤1.5	≤0.04	≤0.04	9.0~12.0	18.0~21.0	2.0~3.0	-	-	-	≥205	≥480	≥33	≤183
	JIS	G5121	SCS14A	≤0.08	≤1.5	≤1.5	≤0.04	≤0.04	9.0~12.0	18.0~21.0	2.0~3.0	-	-	≥205	≥480	≥33	≤183
ASTM	A351 A743 A744	CF-8M	≤0.08	≤1.5	≤1.5	≤0.04	≤0.04	9.0~12.0	18.0~21.0	2.0~3.0	0.10~0.12	-	-	≥205	≥485	≥30	-

飽和蒸氣的溫度壓力對照表

溫度基準			絕對壓力基準			標準壓力基準		
溫度 °C	飽和絕對壓力 kgf/cm ²	飽和標準壓力 kgf/cm ²	絕對壓力 kgf/cm ²	標準壓力 kgf/cm ²	飽和溫度 °C	標準壓力 kgf/cm ²	絕對壓力 kgf/cm ²	飽和溫度 °C
70	0.32	-0.72	1	-0.32	99.1	0	1.03	100.0
80	0.48	-0.55	2	0.97	119.6	1	2.03	120.1
90	0.71	-0.32	3	1.97	132.9	2	3.03	133.2
100	1.03	0	4	2.97	142.9	3	4.03	143.2
110	1.46	0.43	5	3.97	151.1	4	5.03	151.3
120	2.02	0.99	6	4.97	158.1	5	6.03	158.3
130	2.75	1.72	7	5.97	164.2	6	7.03	164.3
140	3.68	2.65	8	6.97	169.6	7	8.03	169.8
150	4.85	3.82	9	7.97	174.5	8	9.03	174.7
160	6.30	5.27	10	8.97	179.0	9	10.03	179.3
170	8.08	7.04	12	10.97	187.1	10	11.03	183.2
180	10.22	9.19	14	12.97	194.1	12	13.03	190.7
190	12.80	11.77	16	14.97	200.4	14	15.03	197.4
200	18.86	17.82	18	16.97	206.2	16	17.03	203.4
210	19.46	18.42	20	18.97	211.4	18	19.03	208.9
220	23.66	22.63	25	23.97	222.9	20	21.03	213.8
230	28.53	27.50	30	28.97	232.8	25	26.03	223.8
240	34.14	33.11	35	33.97	241.4	30	31.03	234.5
250	40.56	39.53	40	38.97	249.2	40	41.03	250.6
260	47.87	46.84	50	48.97	262.7	50	51.03	263.9
270	56.14	55.10	60	58.97	274.3	60	61.03	275.3
280	65.46	64.42	70	68.97	284.5	70	71.03	285.4
290	75.92	74.58	80	78.97	293.6	80	81.03	294.5
300	87.61	86.58	90	88.97	301.9	90	91.03	302.7
310	100.7	99.62	100	98.97	309.5	100	101.0	310.9
320	115.1	114.1	120	119.0	323.1	120	121.0	323.8
330	131.2	130.2	140	139.0	335.1	140	141.0	335.6
340	149.0	147.9	160	159.0	345.7	160	161.0	346.2
350	168.6	167.6	180	179.0	355.4	180	181.0	355.8
360	214.7	213.6	200	199.0	364.1	200	201.0	364.5
370	225.7	224.6	220	219.0	372.0	220	221.0	372.5

橡膠耐高低溫範圍

-80°C -60°C -40°C -20°C 0°C 20°C 40°C 60°C 80°C 100°C 120°C 140°C 160°C 180°C 200°C 220°C

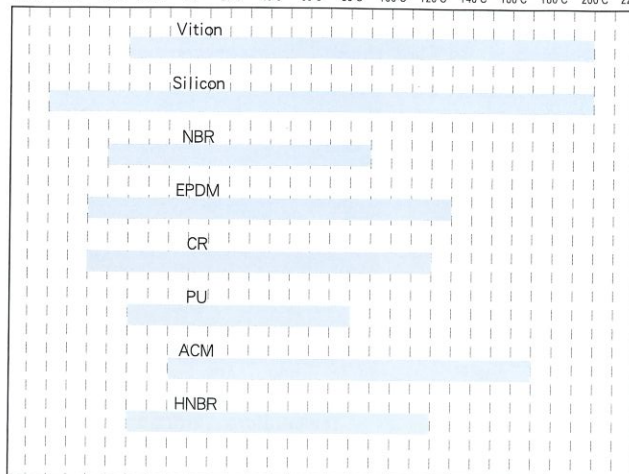

橡膠材質特性表

◎ 優Excellent ○ 良Good ▲ 可Fair × 裂Not Recommend

	Viton	Silicone	NBR	EPDM	CR	PU	ACM
動態特性 Dynamic characteristic							
拉力 Tensile strength	▲	×	○	▲	◎	◎	×
耐磨耗 Abrasion resistance	▲	×	○	○	○	◎	×
耐撕裂 Tear resistance	▲	×	○	▲	○	◎	×
耐撞擊 Impact resistance	▲	×	○	○	◎	◎	×
靜態特性 Static characteristic							
壓縮性 Compression set	○	▲	○	○	◎	◎	▲
耐熱 Heat resistance	○	◎	▲	○	○	◎	▲
耐低溫性 Low temperature resistance	▲	◎	○	○	○	▲	×
耐氣候 Weather resistance	○	◎	○	○	○	◎	○
耐臭氧 ozone resistance	◎	◎	▲	◎	○	◎	○
耐礦物油 Mineral resistance	◎	◎	◎	×	▲	◎	◎
耐汽油 Gasoline Resistance	◎	▲	◎	×	▲	◎	◎
耐酸 Acid resistance	◎	▲	○	○	○	×	×
耐鹼 Alkali resistance	○	▲	○	○	○	×	×
耐甲苯 Toluene resistance	▲	▲	▲	▲	×	▲	▲
耐醇類 Alcohol resistance	○	○	○	○	◎	▲	▲
耐酮類 Ketone resistance	▲	○	▲	○	◎	▲	▲
耐醚類 Ether resistance	▲	○	×	◎	◎	▲	▲
耐水 Water resistance	◎	◎	◎	◎	◎	×	▲
耐燃性 Flame resistance	◎	◎	▲	▲	○	▲	▲

產品壓力、溫度對照表

Pressure-Temperature Ratings

Cast Bronze Valve (MSS SP-80)

Pressure Class	125			150			200			300		
	Threaded	Threaded	Flanged ANSI B16-34	Threaded	Flanged	Flanged	Threaded	Flanged	Flanged	Threaded	Flanged	Flanged
End Connection	ASTM-B62						ASTM-B61					
Temperature Degrees C												
-30 to 65	200	300	225	400	1000	600						
100	185	270	210	375	920	560						
125	170	240	195	350	830	520						
150	155	210	180	325	740	490						
175	140	180	165	300	650	450						
200	-	-	-	275	650	410						
208	125	150	150	-	-	-						
225	-	-	-	250	480	375						
232	120	145	-	-	-	-						
250	-	-	-	225	390	340						
275	-	-	-	200	300	300						

Cast Iron Valve (MSS SP-70)

Class	125(JIS-10K)			250(JIS-16K)		
	End Connection	Flanged			Flanged	
Temperature Degrees C	NPS 2-12	14-24	30-40	NPS 2-12	14-24	
-30 to 65	200	150	150	500	300	
95	190	135	115	450	280	
110	180	130	100	440	270	
125	175	125	85	475	260	
140	170	120	65	395	230	
150	165	110	50	375	240	
165	155	105		355	230	
180	150	100		335	220	
190	145			315	210	
205	140			290	200	
220	130			270		
232	125			250		

STAINLESS STEEL VALVES CLASS150(ANSI 16.34) JIS10K (JIS B2003)

壓力規格		150				300				600				900			
使用溫度 °C	°F	CF8 (SCS 13)		CF8M (SCS 14)		CF8 (SCS 13)		CF8M (SCS 14)		CF8 (SCS 13)		CF8M (SCS 14)		CF8 (SCS 13)		CF8M (SCS 14)	
		psig	kgf/cm ²	psig	kgf/cm ²	psig	kgf/cm ²	psig	kgf/cm ²	psig	kgf/cm ²	psig	kgf/cm ²	psig	kgf/cm ²	psig	kgf/cm ²
-29	-20																
-38	-100	275	19.3	275	19.3	720	50.6	720	50.6	1440	101.2	1440	101.2	2150	151.9	2150	151.9
93	200	235	16.5	240	16.9	600	42.2	620	43.6	1200	84.4	1240	87.2	1800	126.6	1860	130.8
149	300	205	14.4	215	15.1	530	37.3	560	39.4	1065	74.2	1120	78.7	1685	111.4	1680	118.1
204	400	180	12.7	195	13.7	470	33.0	515	36.2	940	66.1	1030	72.4	1410	99.1	1540	108.3
260	500	170	12.0	170	12.0	435	30.6	480	33.7	875	61.5	955	67.1	1310	92.1	1435	100.9
316	600	140	9.8	140	9.8	415	29.2	450	31.6	830	58.4	905	63.6	1245	87.5	1355	95.3
343	650	125	8.8	125	8.8	410	28.8	445	31.3	815	57.3	890	62.8	1225	86.1	1330	93.5
371	700	110	7.7	110	7.7	405	28.5	430	30.2	805	56.6	865	60.8	1210	85.1	1295	91.0
399	750	95	6.7	95	6.7	400	28.1	425	29.9	795	55.9	845	59.4	1195	84.0	1270	89.3
427	800	80	5.6	80	5.6	395	27.8	415	29.2	790	55.5	830	58.4	1180	83.0	1245	87.8
454	850	65	4.6	65	4.6	390	27.4	405	28.5	780	54.8	810	56.9	1165	81.9	1215	85.4
482	900	50	3.5	50	3.5	385	27.1	395	27.8	770	54.1	790	55.5	1150	80.9	1180	83.0
510	950	35	2.5	35	2.5	375	26.4	385	27.1	750	52.7	775	54.5	1125	79.1	1160	81.6
538	1000	20	1.4	20	1.4	325	22.8	365	25.7	645	45.3	725	51.0	965	67.8	1090	76.6
566	1050	20*	1.4*	20*	1.4*	310	21.8	360	25.3	620	43.6	720	50.6	925	65.0	1080	75.9
593	1100	20*	1.4*	20*	1.4*	260	18.3	325	22.8	515	36.2	645	45.3	770	54.1	965	67.8
621	1150	20*	1.4*	20*	1.4*	195	13.7	275	19.3	390	27.4	550	38.7	585	41.1	825	58.0
649	1200	20*	1.4*	20*	1.4*	155	10.9	205	14.4	310	21.8	410	26.8	465	32.7	620	43.6
677	1250	20*	1.4*	20*	1.4*	110	7.7	180	12.7	220	15.4	365	25.7	330	23.2	545	38.3
704	1300	20*	1.4*	20*	1.4*	85	6.0	140	9.8	165	11.6	275	19.2	249	17.2	410	28.8
732	1350	20*	1.4*	20*	1.4*	60	4.2	105	7.4	125	8.8	205	14.4	185	13.0	310	21.8
760	1400	20*	1.4*	20*	1.4*	50	3.5	75	5.3	95	6.7	150	10.5	145	10.2	225	15.8
788	1450	15*	1.1*	20*	1.4*	35	2.5	60	4.2	70	4.9	115	8.1	105	7.4	175	12.3
816	1500	10*	0.7*	15*	1.1*	25	1.8	40	2.8	50	3.5	85	6.0	70	4.9	125	8.8
閥體水壓試驗壓力		425psig 30kg f/cm ²				1100psig 78kg f/cm ²				2175psig 153kg f/cm ²				3250psig 229kg f/cm ²			
閥座 試驗壓力	水壓	303psig 22kg f/cm ²				792psig 56kg f/cm ²				1584psig 112kg f/cm ²				2376psig 168kg f/cm ²			
	空氣壓	80psig 6kg f/cm ²				80psig 6kg f/cm ²				80psig 6kg f/cm ²				80psig 6kg f/cm ²			

BALL VALVES SEAL

Virgin PTFE
Mainteraed PTFE
Carbea-1111pd PTFE

(P-T RATINGS)

2", 2-1/2"

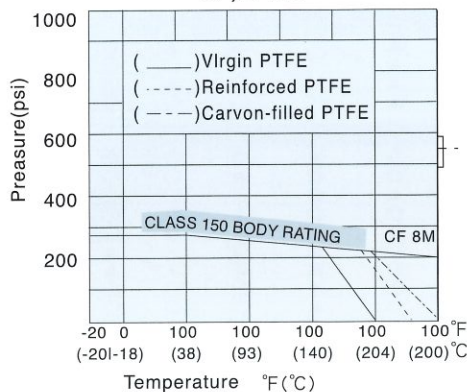

3", 4"

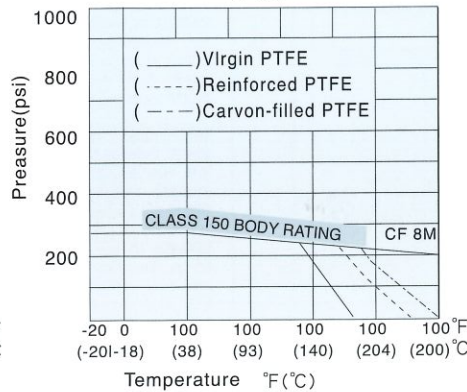



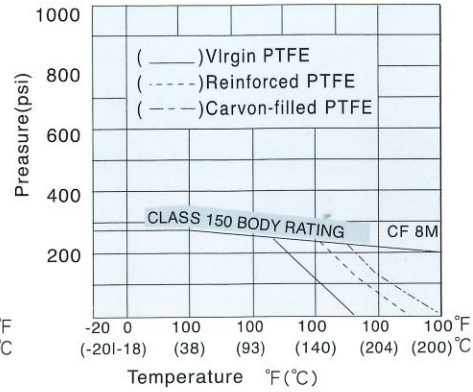



6", 8"

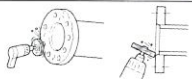

1. 標稱壓力：指120°C以下之油或有變動負荷之水流所能承受之最高容許額定壓力，各部位不得有洩漏或其它異狀。
 說明：(一)125S 300W.O.G(C.W.P.O)
 125S指標稱壓力，300W.O.G指當常溫運作水、油、氣體時、閥座承受壓力為300psi(21kgf/cms)不允許有洩漏現象。
 (二)W.O.G.:指水(WATER)、油(OIL)、氣體(GAS)。
 (三)C.W.P.:冷(COLD)、工作(WORKING)、壓力(PRESSURE)、指當溫(-28.9°C至65.5°C)運作壓力。
 (四)S.W.P.:蒸汽(STEAM)、工作(WORKING)、壓力(PRESSURE)。
 (五)1kgf/cm²=14.2233PSI
2. 流量係數Cv值：當水流的溫度為60°F(15.6°C)時，通過閥之後，壓力差保持為1lb/in²(1PSI)，則每分鐘流過的加侖數量即是Cv值。簡單的說即是每分鐘的出水量。
3. 選擇閥類之各項因素
 - (一)流體特性 如流體種類、比重、黏性、腐蝕性等。
 - (二)構成材質 不同的操作情況如流體種類、操作溫度、壓力、腐蝕性等，選適當之材質。
 - (三)溫度 最高、最低溫度為何。
 - (四)壓降 各種閥類因與流體產生之摩擦導致之壓降各有不同程度。
 - (五)操作壓力 最高壓力為何。
 - (六)閥之尺寸 所有閥之尺寸大小均有一定之範圍限制，因此在決定閥之種類時應一併考慮。
 - (七)操作情況 確定實際之操作頻率為何。
 - (八)其他 如設置場所之週邊環境、空間、功能、規格之限制等。

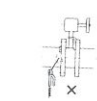
閥配管注意事項

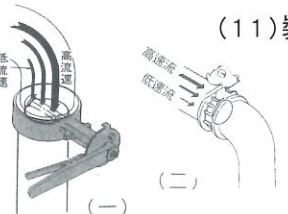
	(1) 配管前先檢查閥門是否有雜物、油污，若有則先予清除，否則雜物常漏水之主因，易造成閥體之損害。
	(2) 法蘭面之內外毛角邊應去除並予倒角。
	(3) 配管後試漏，若有微漏情形，應予開啟，清除雜物後再行關閉，不可用槓桿強行鎖緊。
	(4) 使用於蒸汽管路，閥門欲打開時，應慢慢打開一點後，停住讓蒸汽進入管路預熱之再慢慢打開至需要開度，亦應慢慢關上，直至全關。
	牙口應注意事項
	(5) 管端鎖入閥體時，應注意不可過度鎖入造成閥門變形損壞，甚至形成本體擠裂之破壞。
	(6) 以膠液作牙部封閉介質時，應塗抹於管端牙部，不應塗於閥之內牙上。
	(7) 配管時，應以夾具夾緊管子，再用管鉗咬住閥之六角，管鉗夾住閥體六角之位置應為靠近配管之端，不可夾持在離管較遠之六角端。
	(8) 開啟閥蓋時，在扳手柄處輕輕敲打後轉動旋開，切勿在扳手柄外加長握把使用，使閥蓋損傷漏水。
	法蘭口應注意事項
	(9) 閥裝入管中時，應先作法蘭口與管端之點銲定位，拆下閥體，待銲接管端法蘭口完成，再行裝配，不可於定位時即行完全銲接。
	(10) 裝配閥時，閥中心與管端法蘭中心應保持同心度，避免碰擋流葉片，甚至影響操作。
	(11) 裝配蝶閥時，(一)擋流葉片應由全關旋至稍為打開之角度，不可於全開時作配管鎖緊之動作。 (二)來水端為彎管，管內有壓差沖擊閥桿之位置應放置在有壓差之方向，以防止擋流片因壓差而磨損不平均及定位不穩定。 (三)若出水端為彎管則閥桿之位置應在有壓差之90度角方向，以減少壓降。

法蘭規格表

JIS 10kg/cm²型 FLANGES

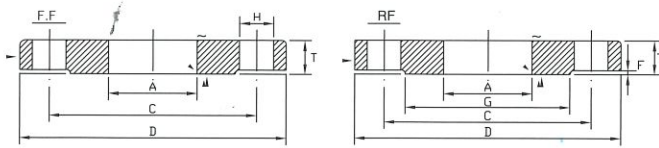

尺寸 (B)	內徑 A	外徑 D	厚 T	座徑 G	座厚 F	中心 C	孔徑 H	孔數 N	螺絲 稱呼吋
1 1/2	50	140	16	85	2	105	19	4	5/8
2	61.5	155	16	100	2	120	19	4	5/8
2 1/2	77.5	175	18	120	2	140	19	4	5/8
3	90	185	18	130	2	150	19	8	5/8
3 1/2	103	195	18	140	2	160	19	8	5/8
4	116	210	18	155	2	175	19	8	5/8
5	142	250	20	185	2	210	23	8	6/8
6	167	280	22	215	2	240	23	8	6/8
8	218	330	22	265	2	290	23	12	6/8
10	270	400	24	325	2	355	25	12	7/8
12	320	445	24	370	3	400	25	16	7/8
14	358	490	26	415	3	445	25	16	7/8
16	409	560	28	475	3	510	27	16	1

ANSI 125型 FLANGES

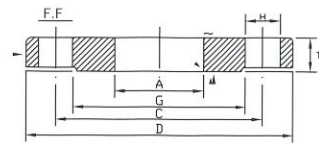

尺寸 (B)	內徑 A	外徑 D	厚 T	中心 C	座徑 G	座厚 F	孔徑 H	孔數 N	螺絲 稱呼吋
1 1/2	50	127	14.3	98.5	16	4	1/2		
2	61.5	152	15.9	120.5	19	4	5/8		
2 1/2	77.5	178	17.5	139.5	19	4	5/8		
3	90	190	19.1	152.5	19	4	5/8		
4	116	229	23.9	190.5	19	8	5/8		
5	142	254	23.9	216.0	22	8	3/4		
6	167	279	25.4	241.5	22	8	3/4		
8	218	343	28.6	298.5	22	8	3/4		
10	270	406	30.2	362.0	25	12	7/8		
12	320	483	31.8	432.0	25	12	7/8		
14	358	533	35.0	476.5	29	12	1		
16	409	597	36.6	539.5	29	16	1		

JIS 16kg/cm²型 FLANGES

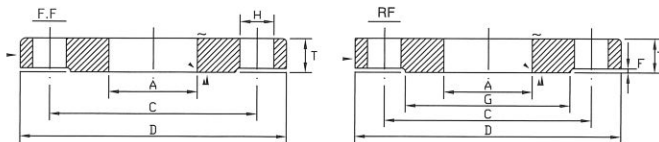

尺寸 (B)	內徑 A	外徑 D	厚 T	座徑 G	座厚 F	中心 C	孔徑 H	孔數 N	螺絲 稱呼吋
1 1/2	50	140	16	85	2	105	19	4	5/8
2	61.5	155	16	100	2	120	19	8	5/8
2 1/2	77.5	175	18	120	2	140	19	8	5/8
3	90	200	20	135	2	160	22	8	3/4
3 1/2	103	210	20	145	2	170	22	8	3/4
4	116	225	22	160	2	185	22	8	3/4
5	142	270	22	195	2	225	25	8	7/8
6	167	305	24	230	2	260	25	12	7/8
8	218	350	26	275	2	305	25	12	7/8
10	270	430	28	345	2	380	29	12	1
12	320	480	30	395	3	430	29	16	1
14	358	540	34	440	3	480	32	16	1 1/8
16	409	605	38	495	3	540	35	16	1 1/4

ANSI 150型 FLANGES

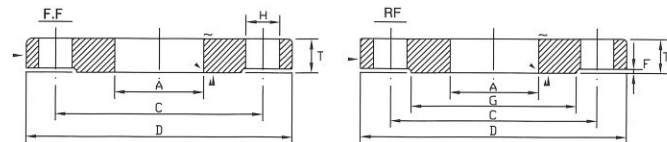

尺寸 (B)	內徑 A	外徑 D	厚 T	中心 C	座徑 G	座厚 F	孔徑 H	孔數 N	螺絲 稱呼吋
1 1/2	50	127	17.5	73	1.6	98.5	16	4	1/2
2	61.5	152	19.1	92	1.6	120.5	19	4	5/8
2 1/2	77.5	178	22.3	105	1.6	139.5	19	4	5/8
3	90	190	23.9	127	1.6	152.5	19	4	5/8
4	116	229	23.9	157	1.6	190.5	19	8	5/8
5	142	254	23.9	186	1.6	216.0	22	8	3/4
6	167	279	25.4	216	1.6	241.5	22	8	3/4
8	218	343	28.6	270	1.6	298.5	22	8	3/4
10	270	406	30.2	324	1.6	362.0	25	8	7/8
12	320	483	31.8	381	1.6	432.0	25	12	7/8
14	358	533	35.0	413	1.6	476.0	29	12	1
16	409	597	36.6	470	1.6	539.5	29	16	1

JIS 20kg/cm²型 FLANGES

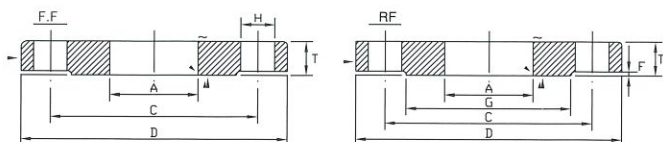

尺寸 (B)	內徑 A	外徑 D	厚 T	座徑 G	座厚 F	中心 C	孔徑 H	孔數 N	螺絲 稱呼吋
1 1/2	50	140	18	85	2	105	19	4	5/8
2	61.5	155	18	100	2	120	19	8	5/8
2 1/2	77.5	175	20	120	2	140	19	8	5/8
3	90	200	22	135	2	160	23	8	3/4
3 1/2	103	210	24	145	2	170	23	8	3/4
4	116	225	24	160	2	185	23	8	3/4
5	142	270	26	195	2	225	23	8	7/8
6	167	305	28	230	2	260	25	12	7/8
8	218	350	30	275	2	305	25	12	7/8
10	270	430	34	345	2	380	27	12	1
12	320	480	36	395	3	430	27	16	1
14	358	540	40	440	3	480	33	16	1 1/8
16	409	605	46	495	3	540	33	16	1 1/8

ANSI 300型 FLANGES

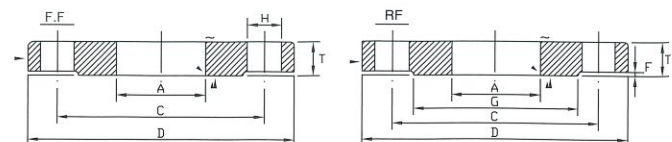

尺寸 (B)	內徑 A	外徑 D	厚 T	中心 C	座徑 G	座厚 F	孔徑 H	孔數 N	螺絲 稱呼吋
1 1/2	50	156	20.7	73	1.6	114.5	19	4	5/8
2	61.5	165	22.3	92	1.6	127.0	22	8	3/4
2 1/2	77.5	190	25.4	105	1.6	149.0	22	8	3/4
3	90	210	28.6	127	1.6	168.0	22	8	3/4
4	116	254	31.8	157	1.6	200	22	8	3/4
5	142	279	35.0	186	1.6	235	22	8	3/4
6	167	318	36.6	216	1.6	270	22	12	3/4
8	218	381	41.3	270	1.6	330	25	12	7/8
10	270	444	47.7	324	1.6	387.5	29	16	1
12	320	521	50.8	381	1.6	451	32	16	1 1/8
14	358	584	54.0	413	1.6	514.5	32	20	1 1/8
16	409	648	57.2	470	1.6	571.5	35	20	1 1/4



富山精機廠股份有限公司
富鋼股份有限公司

彰化縣埔鹽鄉埔港路63-30號

業務專線：(04)866-0888(代表號) FAX：(04)866-0999

E m a i l：fukungtw@ms75.hinet.net

● 本公司對型錄所列產品內容，保有增刪之權力

